



# **Vanagon/Type II Fuel Systems**

The ProTraining booklets have been designed for the professional technician. This ProTraining program is designed to help you understand how fuel systems work and how to fix them. Our goal is to help you to be able to fix the customer's car right . . . the first time.

This booklet is divided into 3 sections; A.F.C., Digijet, and Digifant Fuel Injection Systems. Each section contains:

- System Operation
- Component Description
- Diagnoses and Repair Information

Fuel Systems can be repaired by following the step by step procedures shown in this book.

### **Make Sure You Understand The Customer's Complaint**

- Identify the symptoms as you follow the diagnosis procedure. Try to locate the cause of the problem.
- Repair the problem after you have identified the symptoms.
- After completing the repairs, always road test the vehicle before returning the car to the customer.

# Troubleshooting Guidelines

---

## Preliminary Checks

A complaint may be caused by a minor detail. Before starting the fault finding procedure make a few visual checks, such as:

- Are all electrical plugs/spark plug wires correctly connected (hanging loose, etc.)?
- Are all hoses okay? Check vacuum, crankcase ventilation, fuel tank ventilation, air intake hoses for restrictions, cracks, or looseness.
- Are all the ground connections okay? (clean, tight, etc.)
- Is there adequate fuel supply?

## Mechanical/Electrical Checks

- Before checking, determine that the engine is in sound condition.
- Check battery and charging system. Assure that both systems are functional and in good condition.

## Symptom Oriented

- Due to the interactions of many components in these systems, the troubleshooting guidelines have been written in a progressive sequence which must be followed exactly as written unless otherwise indicated. When checking a problem in a system, the guide will take you through the complete system.

Do not skip any of the test steps in the procedures.

## Pinpointing the Problem

Remember the basics:

- No matter how advanced the system, to start and run an engine, you need correct spark timing, and the proper fuel to air ratio.
- Get as much information as possible from the customer.
- Gather as many symptoms as possible:
  - Look for spark
  - Listen for the fuel pump
  - Feel the injectors operating, etc.
- Make logical deductions, not assumptions.
- Follow the guide, don't shortcut!

# Troubleshooting Guidelines (Cont'd.)

---

## Intermittent Engine Performance Complaints

Intermittent performance complaints can be caused by any part of the electrical, ignition or fuel system. Therefore, obtain as much information as possible from the customer. Try to find out under what conditions the problem occurs. For example: Engine cold, engine warm up, under load, deceleration, light acceleration, city or highway driving. If possible road test the vehicle to duplicate the condition.

When troubleshooting intermittent engine performance complaints:

- Pay very close attention to electrical connections on the fuel injection harness. Connectors which have insufficient tension or show signs of corrosion should be replaced and **not repaired**.
- Corroded and/or loose ground connections should be cleaned and tightened.
- The complete fuel system should be checked including the fuel quality.



## System Components

System Operation .....	95
Electronic Control Unit (E.C.U.) .....	97
Coolant Temperature Sensor .....	98
Fuel Pump .....	98
Air Flow Sensor .....	99
Intake Air Temperature Sensor .....	99
Pressure Regulator .....	100
Injectors .....	100
Throttle Switch .....	101
Fuel Filters .....	101
Oxygen Sensor .....	102
Ignition System .....	103
Idle Stabilizer .....	104
Crankcase Ventilation .....	105
Evaporative Emissions System .....	106

## Checking/Adjusting

Air Flow Sensor .....	107
Intake Air Temperature Sensor .....	107
Coolant Temperature .....	108
Fuel Pump .....	109
Pressure Regulator .....	111
Injectors .....	112
Throttle Switch .....	115
Oxygen Sensor .....	118
Ignition Sensor .....	119
Idle Stabilizer .....	121
Evaporative Emissions System .....	124

<b>Basic Checks And Adjustments</b> .....	125
---	-----

<b>Electrical Testing</b> .....	129
---------------------------------	-----

<b>Wiring Diagram</b> .....	130
-----------------------------	-----

<b>Glossary/Component Location</b> .....	132
--	-----

# Troubleshooting Guidelines

---

## • Engine will not start, hot or cold

- a. No fuel
  - Page 109 Fuel System (Circuit Tests)
  - Page 113 Injector System (Circuit Tests)
  - Page 107 Air Flow Sensor
- b. No spark
  - Page 119 Ignition System

## • Hard starting, hot or cold

- a. No fuel or excessive fuel
  - Page 108 Coolant Temperature Sensor
  - Page 109 Fuel System
  - Page 111 Residual Pressure Test
  - Page 124 Evaporative Emissions System
- b. No spark
  - Page 119 Ignition System

## • Poor idle

- a. At operating temperature
  - Page 115 Throttle Switch
  - Page 121 Idle Stabilizer System
  - Page 124 Evaporative Emissions System
- b. Cold engine
  - Page 108 Coolant Temperature Sensor
  - Page 121 Idle Stabilization System

## • Engine stalls at highway speeds

- a.
  - Page 109 Fuel System (Pressure, Volume, Current Draw Tests)
  - Page 124 Evaporative Emissions System
  - Page 125 Basic Adjustments/Specs
  - Page 129 Ground and Terminal Connections

# Troubleshooting Guidelines (Cont'd.)

---

## • Poor performance

### a. During warm-up

- Page 108 Coolant Temperature Sensor
- Page 115 Throttle Switch
- Page 121 Idle Stabilizer System

### b. At operating temperature

- Page 109 Fuel System (Pressure, Volume, Current Draw Tests)
- Page 115 Throttle Switch
- Page 119 Ignition System
- Page 121 Idle Stabilizer System

### c. At full throttle

- Page 109 Fuel System (Pressure, Volume Tests)
- Page 116 Throttle Switch (Full Throttle Enrichment)
- Page 119 Ignition System

## • High fuel consumption

### a.

- Page 109 Fuel System (Pressure, Volume Tests)
- Page 112 Fuel Injector System (Spray Pattern, Leakage Tests)
- Page 116 Throttle Switch (Full Throttle Enrichment)
- Page 124 Evaporative Emissions System (Leakage Test)



## Electronic Control Unit (E.C.U.)

The Digifant electronic control unit incorporates all the functions of the fuel system and ignition system and provides both the actuation signal for the fuel injectors and optimum ignition timing point for all engine operating conditions.

Injection duration opening signals are provided based on the following inputs:

- Engine speed
- Intake air volume
- Coolant temperature
- Oxygen content in the exhaust gas

- Battery voltage
- Throttle position
- Intake air temperature

The injector opening time is taken from a program in the control unit at 16 points for RPM and 16 points for load for a total of 256 operational points. Injection times can be determined between these fixed points for a total of 65,000 theoretical different opening duration points.

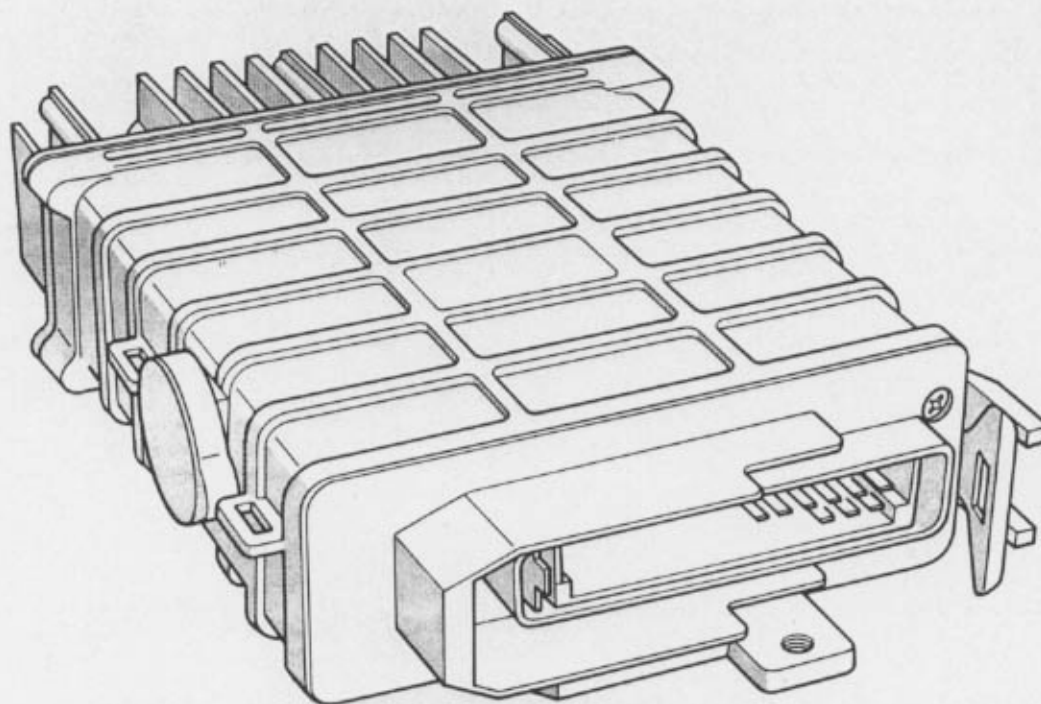

## System Operation

The 2.1 liter Vanagon engine is equipped with Digifant fuel and ignition control system. Digifant is a development of the Digi-Jet fuel injection system combined with the map controlled digital ignition system.

Through the use of a single control unit, all of the functions of the fuel system, ignition system and oxygen sensor system are carefully controlled to provide optimum mixture and ignition control for

improvements in acceleration, deceleration and overall driveability.

The Digifant system features a larger throttle bore diameter, increased from 45 mm to 50 mm.

An idle stabilization system has been incorporated to further streamline the system and eliminates the need for a digital idle stabilizer and auxiliary air regulator.

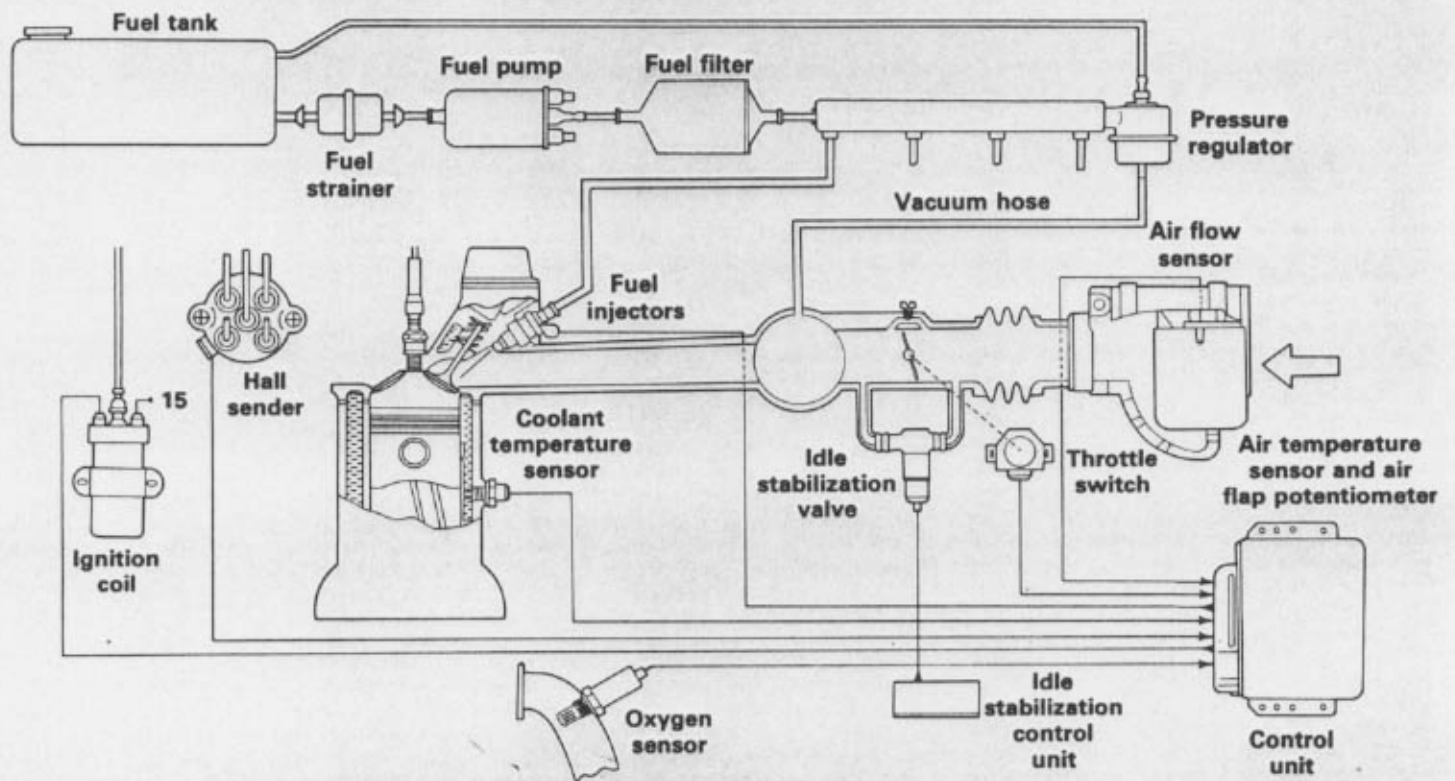

# Special Tools Required

---

## Minimum Requirement

US 1115 L.E.D. Test Light (Leads must be connected RED to positive and Black to negative)

VW 1367 Tester

US 1119 Multi-Meter (digital)

US 1076 or VW 1318 with Adapter VW 1318/17 Pressure Gauge

VW 1473 Voltage Splitter

Sun 120.239 CO Adapter

VW 1315A/2 Adapter Harness

Sun 105 CO Tester

US 8026 Hand Vacuum Pump

US 4487 Evaporator System Leak Tester (slack tube)

VW 1490 Resistance Block (15K ohms/0 ohms)

US 4480/3 Fuel Pump Switch (Optional)

## Obtain Locally

1 Liter Graduated Glass Container

# System Operation

The individual components of the Digifant system work together to manage all aspects of engine operation.

Fuel injection control is electronic and is based on the measurement of air entering the intake and on engine speed measured by the Hall sender. The coolant temperature sensor provides correction during engine starting and warm up.

The oxygen sensor, intake air temperature

sensor and throttle switch provide the control unit with additional information to assure smooth performance under all driving conditions. A separate control unit is used for the idle stabilization valve.

Ignition timing control is determined by an engine speed signal from the Hall sender, and a load signal from the air sensor. A signal from the coolant temperature sensor provides a correction factor.

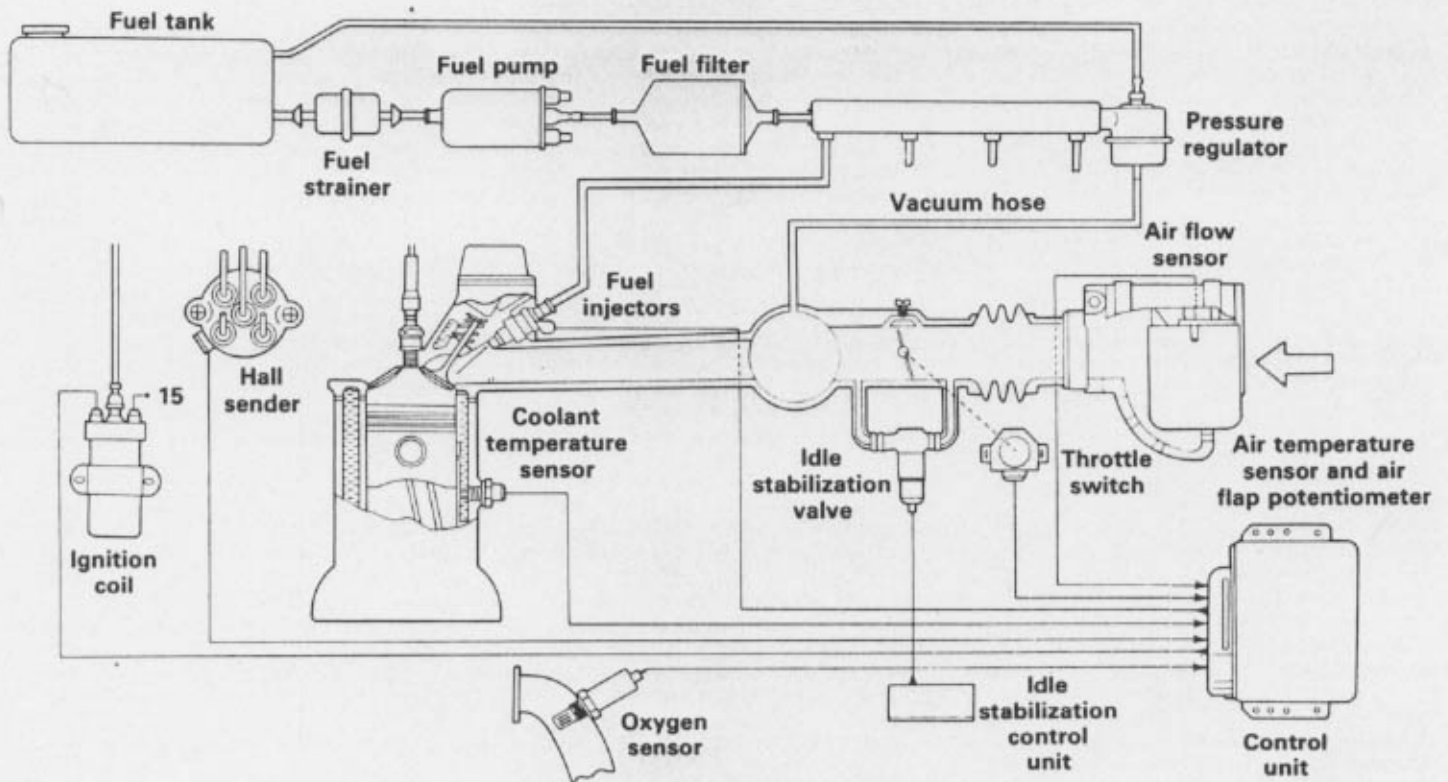

# Component Description

## Coolant Temperature Sensor

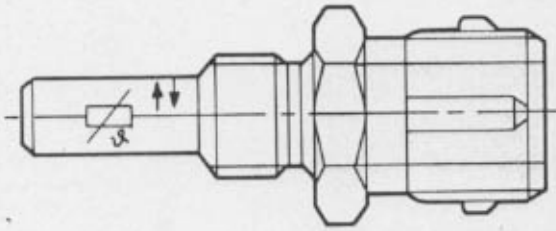

The coolant temperature sensor is a negative temperature coefficient resistor (NTC). The resistance signal it produces is used by the control unit to determine:

- The amount of cold start and warm-up enrichment
- Ignition timing and idle stabilization during warm-up
- When the oxygen sensor, idle stabilization, and full throttle enrichment functions are activated

## Fuel Pump

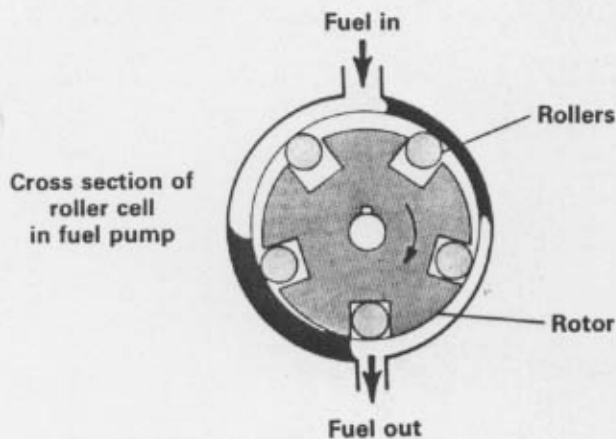

The fuel pump is a roller cell design. It is driven by a permanent magnet electric motor and is located near the fuel tank.

Steel rollers are held in "cut-outs" on the rotor. Centrifugal force seals the rollers against the walls of the pressure chamber as the rotor spins. Fuel that is trapped between the rollers is forced out the delivery port. The pump is designed to be both cooled and lubricated by the fuel flowing through it.

The pump delivers several times the amount of fuel needed to operate the engine at any time. Excess fuel is returned to the fuel tank via the fuel pressure regulator.

# Component Description

## Air Flow Sensor

The air flow sensor measures the amount of air entering the intake manifold and sends a voltage signal to the control unit.

Intake air opens the air flow sensor flap which actuates the potentiometer to determine the voltage signal. This signal and the engine speed information supplied by the Hall sender are used as the principal inputs for the determination of fuel injector opening duration and ignition timing points.

A compensation flap connected to the air sensor dampens sudden movements of the air sensor flap due to oscillations of the intake air.

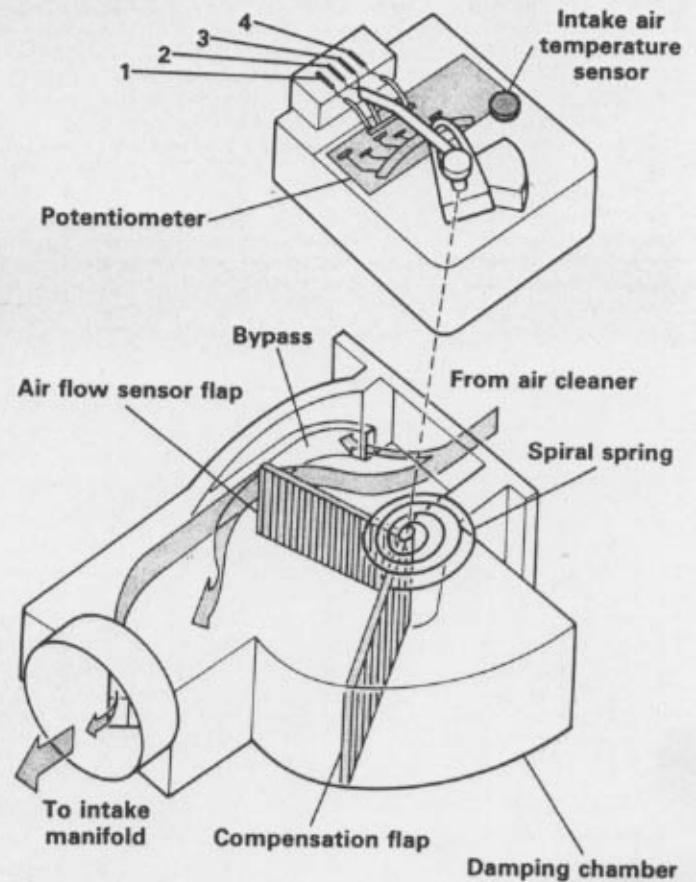

## Intake Air Temperature Sensor

An intake air temperature sensor is mounted in the air flow sensor housing. It is a negative temperature coefficient (NTC) resistor, which means its resistance value drops as its temperature increases. The signal it supplies to the control unit is used to modify fuel injection rate depending on intake air temperature. The sensor can be tested by measuring the resistance value of the sensor and comparing the reading to a graph.

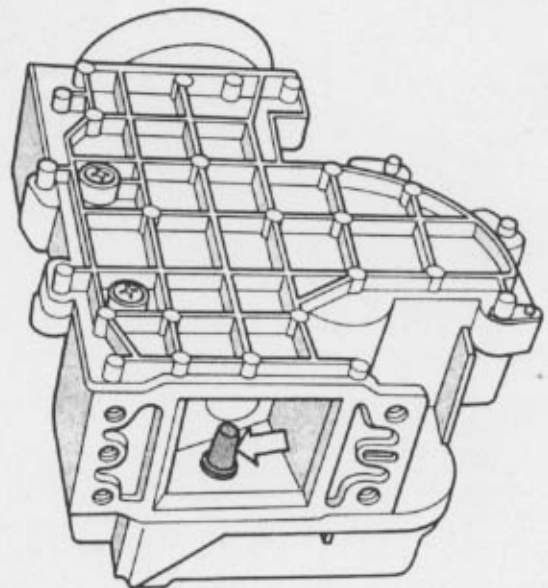

# Component Description

## Fuel Pressure Regulator

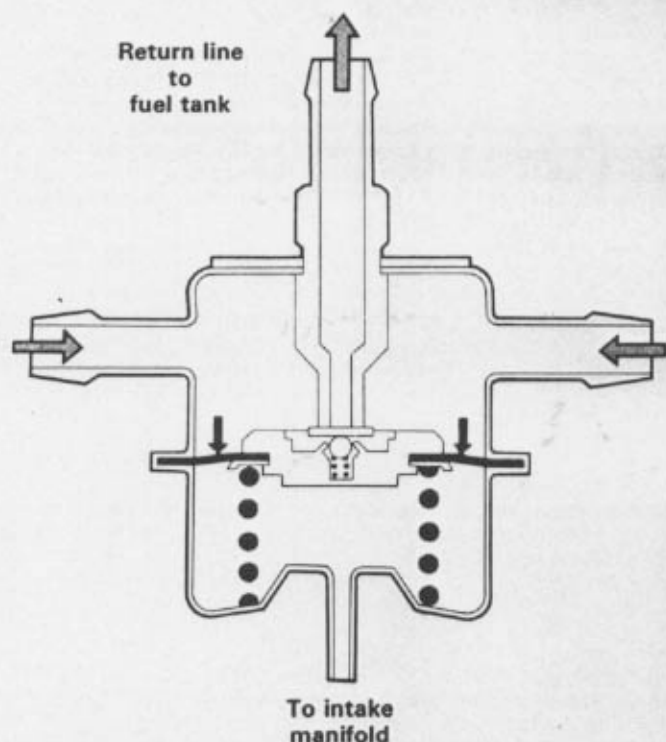

The system pressure regulator maintains a constant fuel pressure to all injectors by regulating the quantity of fuel returned to the fuel tank.

The regulator is connected to the intake manifold. It responds to manifold vacuum fluctuations, and thereby compensates for engine-load changes.

When the engine is shut off, the regulator closes and seals to maintain residual fuel pressure in the injector lines for improved hot-start capability.

## Fuel Injectors

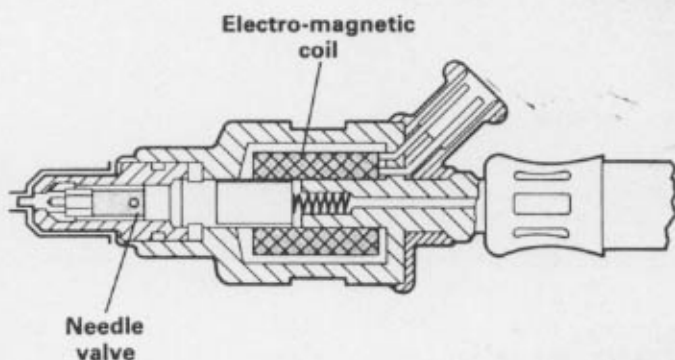

Digifant fuel injectors are electronically controlled on/off valves. A solenoid actuates a needle valve allowing fuel to be forced through the injector nozzle. All four injectors open at the same time and inject fuel directly into the intake manifold near the intake valve. Injection quantity is controlled by the amount of time the injectors stay open. Injector opening time is regulated by the E.C.U., based on inputs from the various engine sensors.

**Note:** Digifant injectors (yellow body) are not interchangeable with A.F.C. injectors (blue body).

# Component Description

## Throttle Switch

Digifant uses a single throttle switch to signal the E.C.U. when the throttle plate is in the fully closed (idle) or fully open (full load) position. The signal enables the E.C.U. to determine that one of three auxiliary functions (idle stabilization, deceleration fuel shut-off, or full load enrichment) is required and activate the appropriate circuit.

The throttle switch is an NOC switch, or **normally open unless** actuated. The contact arm is actuated by a cam with two eccentrics which attaches to the throttle plate shaft. One eccentric closes the contacts in the fully closed (idle stabilization or decel fuel shut-off) position, and the other in the fully open (full load enrichment) position.

Correct adjustment of the throttle switch is very important. If switch is misadjusted, engine may surge at idle or cut out during steady driving or light acceleration.

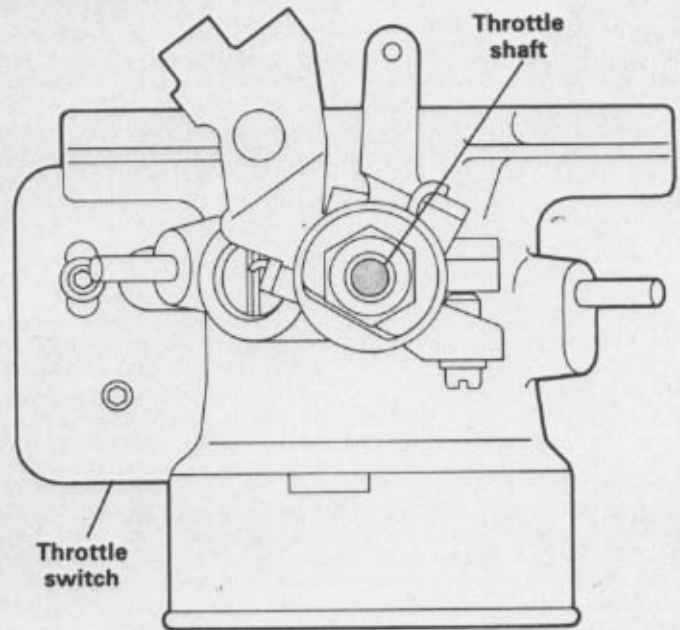

## Fuel Filters

Two types of fuel filters are used on the Digifant system.

One is a square plastic fuel strainer which is mounted before the fuel pump to protect it from foreign particles.

The main fuel filter is a metal cylinder which mounts behind the fuel pump. It has a finer filtering mesh to protect the injection components.

Both are lifetime filters and do not require replacement under normal circumstances.

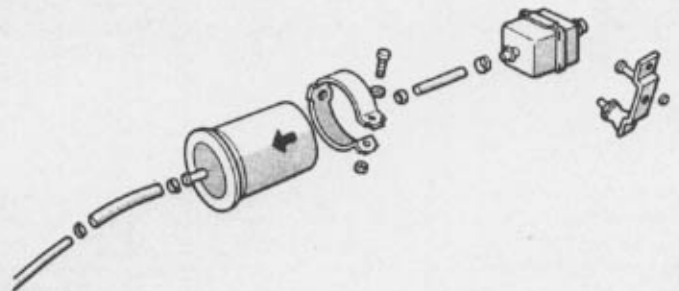



# Component Description

## Oxygen Sensor

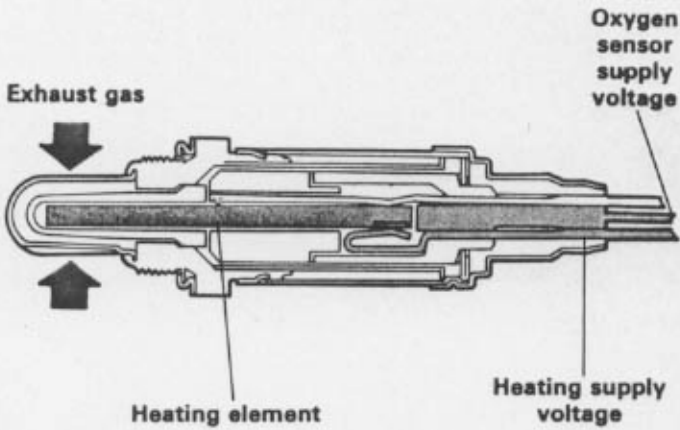

The oxygen sensor is made of a ceramic material called Zirconium dioxide. The inner and outer surfaces of the ceramic material are coated with platinum. The outer platinum surface is exposed to the exhaust gas, while the inner surface is exposed to the outside air.

The difference in the amount of oxygen contacting the inner and outer surfaces of the oxygen sensor creates a pressure differential which results in a small voltage signal in the range of 175 to 1100 (0.175-1.1V) mV being supplied to the E.C.U. The amount of voltage that is produced is determined by the fuel mixture. A high voltage signal indicates a rich mixture, and a low voltage signal indicates a lean mixture.

The oxygen sensor is heated electrically to keep it at a constant operating temperature. This insures continuous and accurate reaction of the sensor during all operating conditions.

The heated oxygen sensor has three wires, two for the heating element (ground and power) and a signal wire for the oxygen sensor. Power is supplied to the heating element whenever the ignition is on.

The oxygen sensor has a 60,000 mile replacement interval. A mileage counter will activate a warning light on the dash at 60,000 miles. At this time, the oxygen sensor should be replaced and the mileage counter reset.

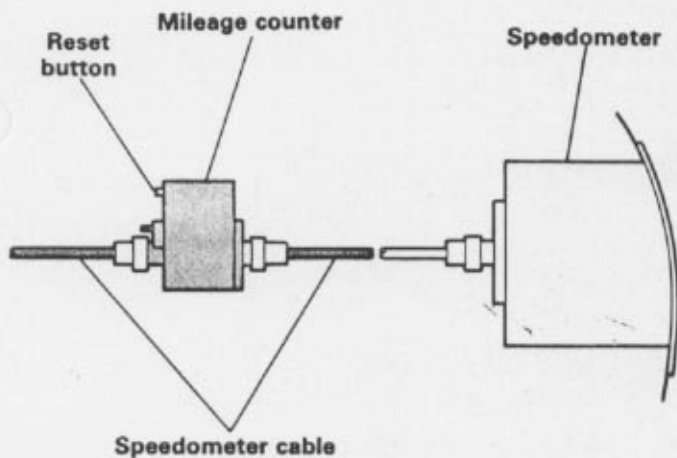

## Ignition System

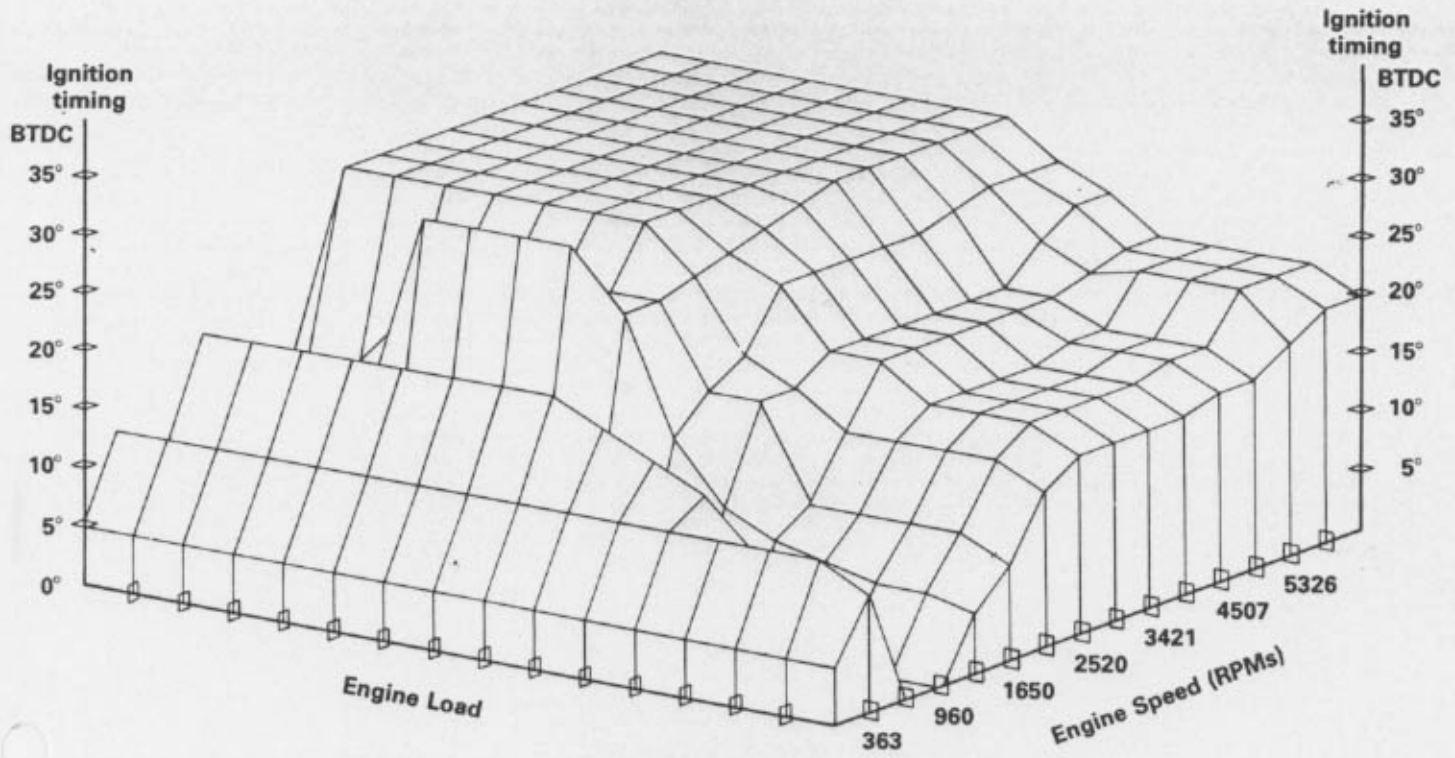

The map controlled ignition system operates on the principle of a timing map which is programmed into the E.C.U. Information on engine load, speed and coolant temperature are provided to the E.C.U. in the form of voltage signals. In the E.C.U. these signals are processed so that the ignition coil is controlled via terminal #1 in accordance with the programmed ignition map. The separate ignition control unit and digital idle stabilizer used in the past have been eliminated.

An engine speed signal comes from the Hall sender in the distributor, and measurement of engine load is accomplished through a signal from the air sensor potentiometer. These two

signals establish the ignition timing point. They are stored in the ignition map in the control unit's memory as 256 single operational points, 16 fixed points for each engine load point and 16 for each RPM point.

The engine coolant temperature sensor signals the control unit to determine ignition timing based on engine temperature. Throughout the engine warm-up phase, ignition timing is constantly being corrected.

Once the engine reaches operating temperature, the timing is determined by the map shown.

## Idle Stabilization

The idle stabilization system used on the Digifant system insures that the idle speed remains constant at predetermined levels. The system controls the amount of air bypassing the throttle plate.

If engine idle speed varies from the value stored in the control unit, the idle stabilizer valve will adjust the volume of air entering the engine at idle. This maintains idle speed within certain limits.

The idle stabilizer valve is operated by a control unit located in the engine compartment near the air cleaner intake hose. The control unit receives

inputs from the following components:

- Throttle switch
- Coolant temperature sensor
- A/C compressor clutch
- Ignition coil terminal #1
- Automatic transmission selector switch
- Power steering pressure switch

With this system, the auxiliary air regulator and digital idle stabilizer are eliminated and any periodic idle adjustment is no longer required.

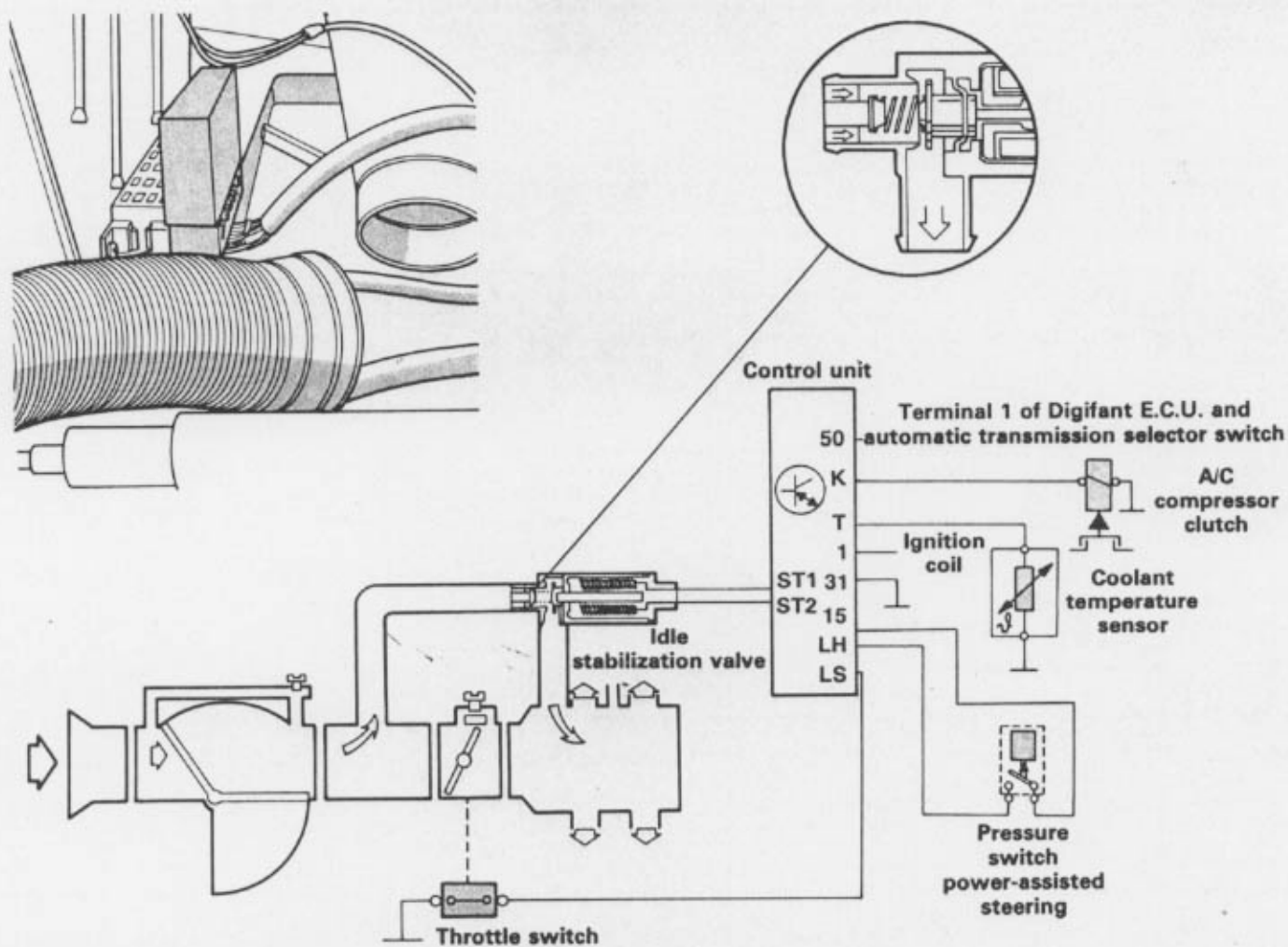

# Component Description

## Crankcase Emission Control

Crankcase vapors are drawn through a breather valve and vapor separator into the intake manifold where they are distributed to all cylinders.

The breather valve operates via intake manifold vacuum. When manifold vacuum is high, such as

at idle and during deceleration, the valve is closed as spring pressure on the valve seat is overcome. As manifold vacuum drops, such as at highway speeds, the valve opens to allow more vapors to be admitted into the intake manifold.

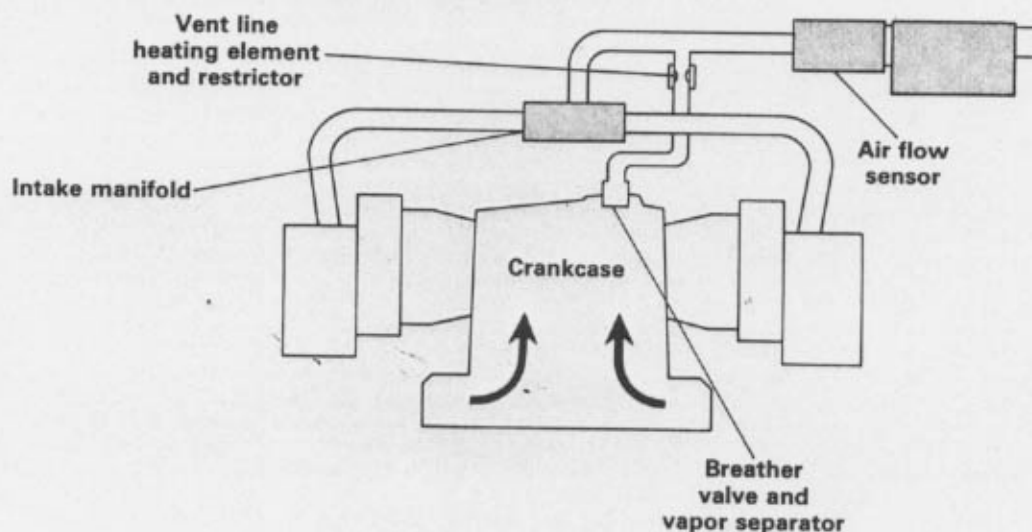

## Vent Line Heating Element

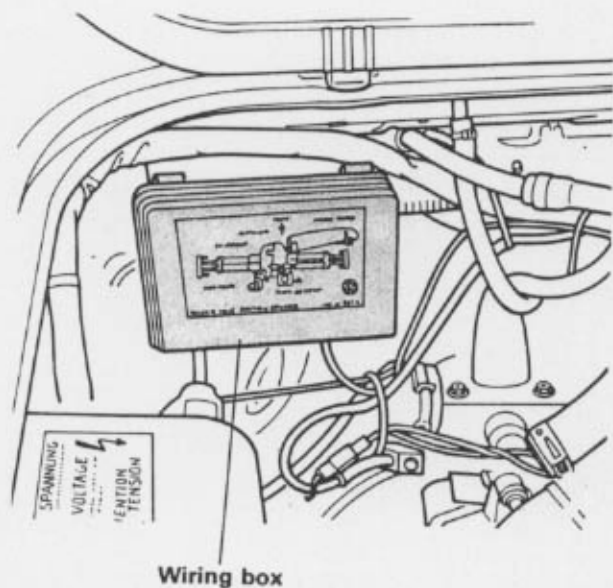

A heating element is used in the crankcase vent line to prevent icing during cold engine operation. This element has a 5.5 mm hole in the restrictor plate. The element can be checked with an ohmmeter. Resistance should be between 4 ohms and 17 ohms at 25°C (77°F).

The circuitry to operate the heating element is protected by an in-line, 5 amp fuse (SAE type) located in the wiring connector box in the engine compartment.

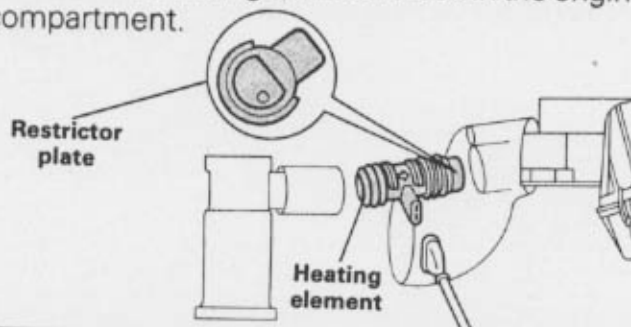

# Component Description

## Evaporative Emission System

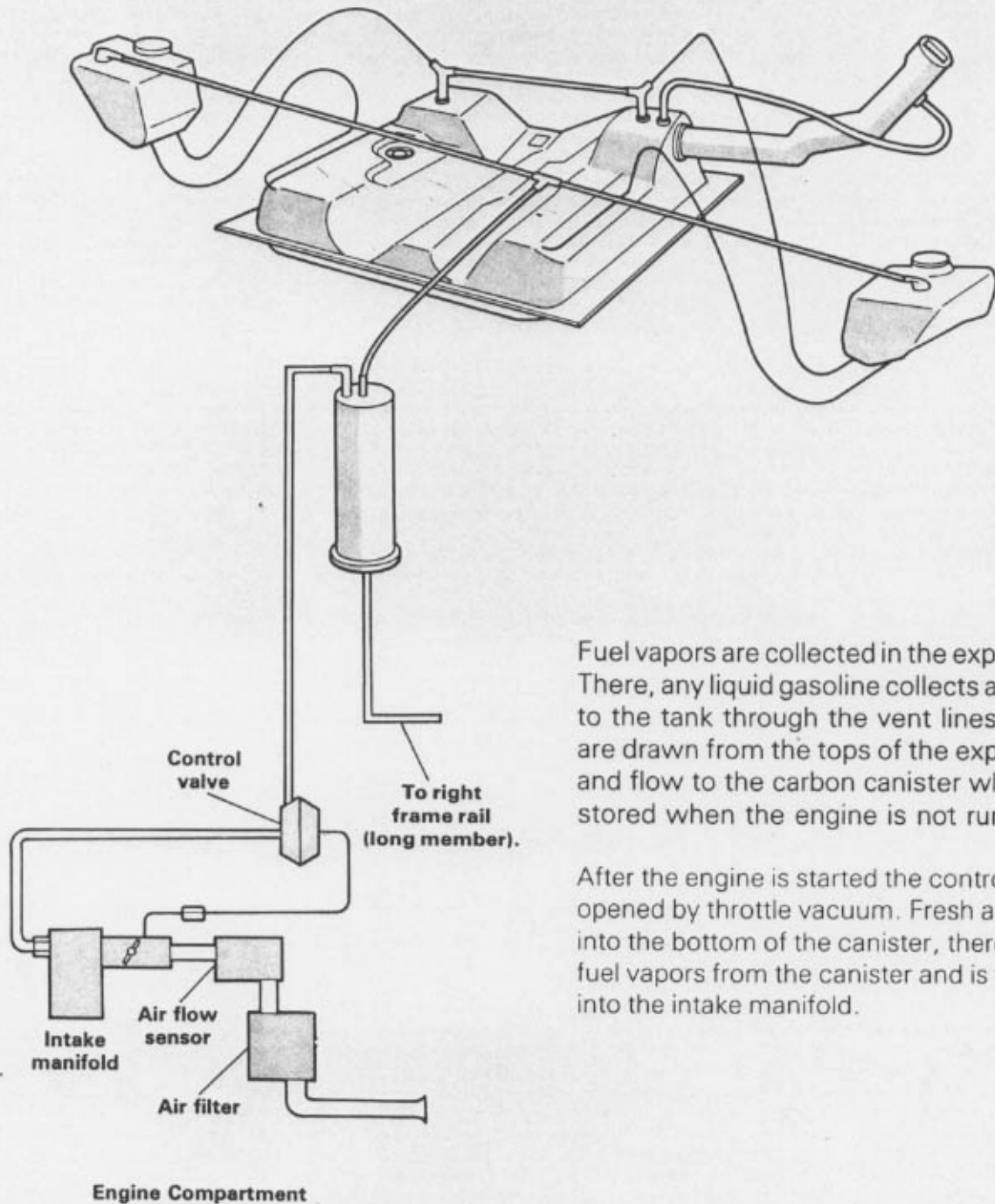

Fuel vapors are collected in the expansion tanks. There, any liquid gasoline collects and flows back to the tank through the vent lines. Fuel vapors are drawn from the tops of the expansion tanks and flow to the carbon canister where they are stored when the engine is not running.

After the engine is started the control valve is opened by throttle vacuum. Fresh air is drawn into the bottom of the canister, there it collects fuel vapors from the canister and is then drawn into the intake manifold.

# Checking/Adjusting

## Air Flow Sensor/Intake Air Temperature Sensor — Checking

### Wiring And Component Checking

The following tests are to verify proper function of the air flow sensor, related wiring and connectors.

- Ignition Off
  - Disconnect multi-pin connector from E.C.U.
  - Connect ohmmeter to terminals of multi-pin connector to test wiring and air flow sensor. (See column "A" for terminal numbers)
  - If readings do not meet specifications:
    - Disconnect electrical connector at air flow sensor.
    - Connect ohmmeter to terminals shown in column "B" to connector pins of air flow sensor to test component.
- If okay — check wiring.  
If not — replace air flow sensor and retest.

Column "A"  
Connections at  
E.C.U. Multi-Pin  
Connector

Column "B"  
Connections at  
Air Flow Sensor

Terminal Nos.	Terminal Nos.	Description	Specification
6 and 17	3 and 4	Potentiometer - Total Resistance	500 - 1000 OHMS
17 and 21	2 and 4	Potentiometer - Resistance Measured Through Wiper Arm	Ohms Change As Sensor Flap Is Opened (Flap Must Move Freely)
6 and 9	1 and 4	Intake Air Temperature Sensor	Ohmmeter Reading Should Correspond To The Graph Below

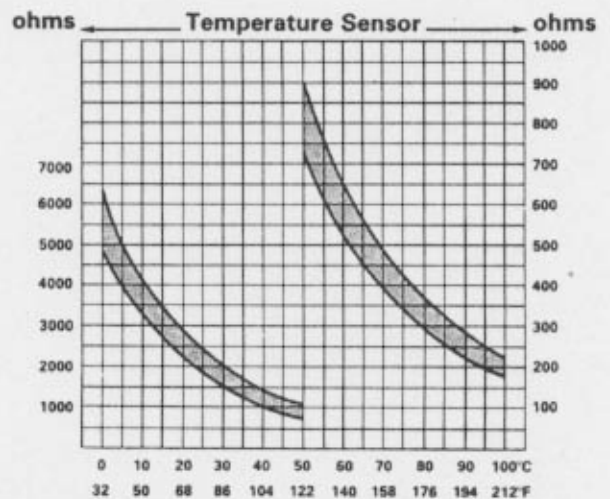
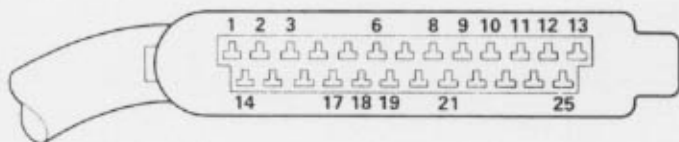

# Checking/Adjusting

## Coolant Temperature Sensor — Checking

The following checks are to verify proper function of the coolant temperature sensor, related wiring and connectors.

- Ignition Off
  - Disconnect multi-pin connector from E.C.U.
  - Measure temperature of coolant temperature sensor with probe type thermometer.
  - Connect ohmmeter to terminals 6 and 9 of multi-pin connector of E.C.U. Resistance value should correspond with graph below.
- If resistance is not within specifications:
    - Disconnect connector from coolant temperature sensor at sensor. (Caution — do not let connector contact exhaust manifold.)
    - Connect ohmmeter to terminals of coolant sensor. Resistance should correspond to graph below. If not, replace sensor.
  - If okay: check wiring.

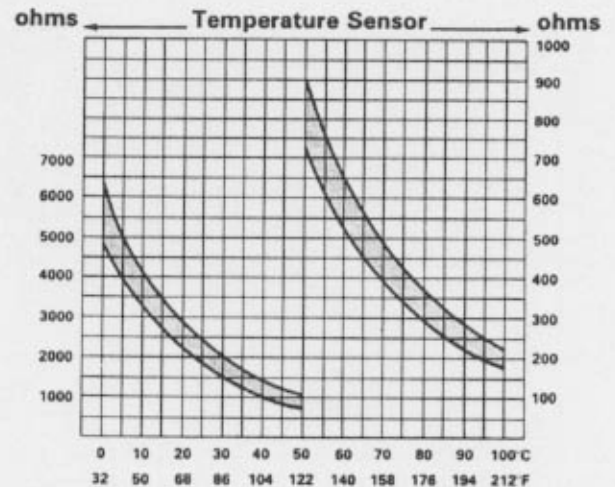
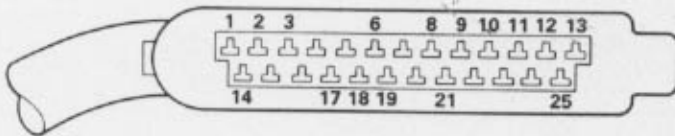

## Fuel Pump Checking

### Pressure Test

- Connect pressure gauge US 1076 or VW 1318 (or equivalent) to fuel line T-piece.

**Note:**

If using VW 1318 pressure gauge, the lever must be in a closed position.

- Remove fuel pump relay and bridge terminals 30 and 87 with tool US 4480/3.

- Run fuel pump and observe pressure.

- Pressure must be a minimum of 2.5 bar (36 PSI)

If not — continue with next test.

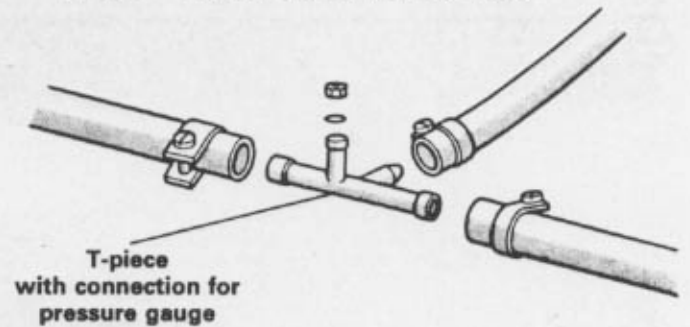

### Volume Test (Fuel Tank At Least Half Full)

- Disconnect fuel return line at pressure regulator.
- Attach approx. 4 feet of fuel line to return line of pressure regulator. Place other end of fuel line into a 1 liter measuring container.
- Remove fuel pump relay and bridge terminals 30 and 87 with tool US 4480/3.
- Run fuel pump exactly 30 seconds.

- Delivery quantity should be at least 500 cc.

If delivery quantity is not to specifications, check fuel flow from tank before and after fuel filters.

If fuel flow from tank is not obstructed, continue to Fuel Pump Electrical Testing below.

### Fuel Pump Electrical

- Battery fully charged.
- Connect ammeter to fuel pump in series with power supply to fuel pump.
- Remove fuel pump relay, bridge terminals 30 and 87 with tool US 4480/3.

- Ammeter readings should be approximately 2.5 - 3.5 amps.

Lower reading may indicate poor ground.

Higher reading may indicate dragging pump motor, pump must be replaced.





## Fuel Pressure Regulator Checking

- Connect pressure gauge US 1076 or VW 1318 (or equivalent) to fuel line T-Piece.

### Note:

If using VW 1318 pressure gauge, the lever must be in a closed position during measurement procedure.

- Run engine at idle speed and check pressure.

### Specifications:

Bar (P.S.I.)	Vacuum Hose on Pressure Regulator
2.2 (33)	Connected
2.5 (36)	Disconnected

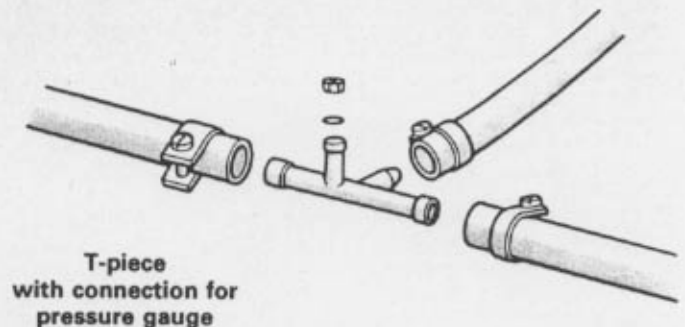
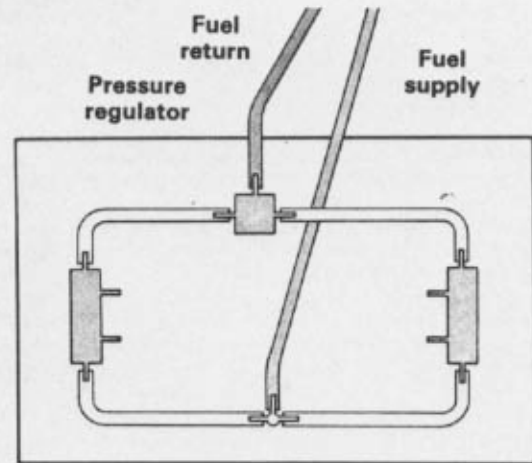

## Residual Pressure Test

- Stop engine, wait 10 minutes. Pressure should be 2.0 - 2.5 bar (29-36 PSI). If not, there are three possible problems:
  - Fuel pump check valve - Test by clamping off line from fuel pump.
  - Fuel pressure regulator - Test by clamping off return line to tank.
  - Fuel injector(s) - Test by clamping off lines from injectors to pressure regulator. If necessary, proceed to page 113 for instructions on leak testing individual injectors.
- Observe pressure gauge while clamping off each of these individual lines. If pressure drop ceases or slows dramatically, problem is in the indicated component. Use care not to damage lines with clamping device.

# Checking/Adjusting

## Fuel Injectors — Checking

### Spray Pattern

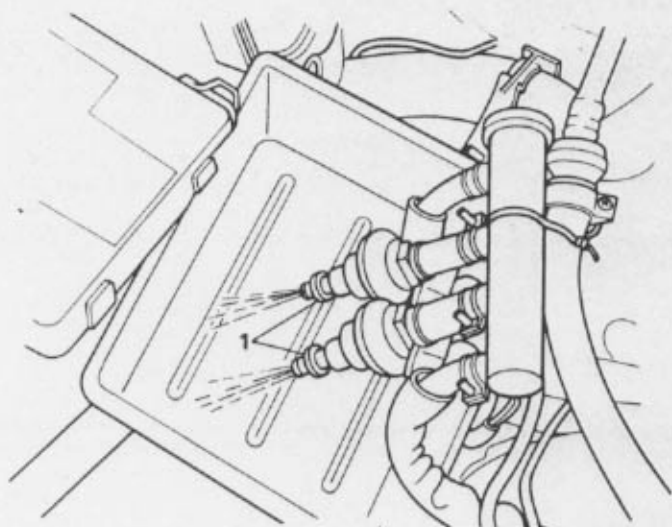

- Remove fuel injectors in pairs (left bank or right). Leave wires connected to injectors.
- Disconnect electrical plugs from injectors which remained installed.
- Hold injectors in jar or pan with paper towel in bottom of pan.
- Operate starter briefly.
  - Spray pattern must be even, coneshaped
- Reinstall fuel injectors with new sealing rings 1.
- Repeat procedure for remaining pair of injectors.

### Quantity

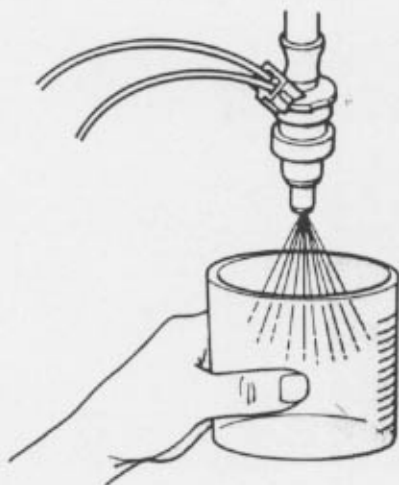

- Disconnect electrical plugs from injectors.
- Pull out injector to be tested and place in graduated container.
- Connect jumper wires to injector to be tested, one from terminal 15 of ignition coil and one from ground.
- Switch on ignition.
- Remove fuel pump relay, bridge terminals 30 and 87 with tool US 4480/3. Run pump for exactly 30 seconds. Delivery quantity must be a minimum of 87 cc after 30 seconds.  
If not: replace injector and retest.
- If still not to specifications, check fuel pump volume as per page 109.

## Fuel Injectors — Checking (Cont'd.)

### Leak Checking

- Remove electrical plugs at fuel injectors.
- Remove injectors in pairs but leave connected to fuel ring line.
- Turn ignition ON for about 5 seconds (fuel pump operates briefly).
- Check that no more than 2 drops leak from each injector in one minute.

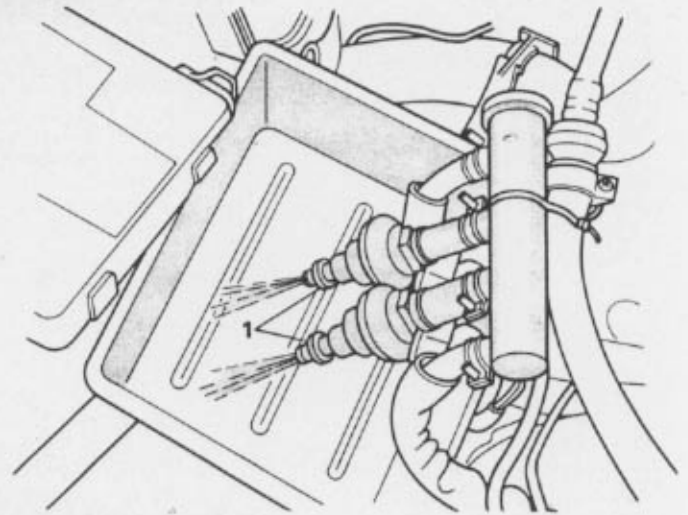

### Component Tests

- Remove electrical plugs at fuel injectors.
- Connect ohmmeter across injector

terminals, reading should be approximately 16 ohms (14-18 ohms).

### Wiring Test

Touch the injectors while cranking the engine. You can feel the mechanical operation of the injector, and the function of the electro-magnetic solenoid.

If not, turn ignition off and remove multi-pin connector plug from the E.C.U. Reconnect electrical plugs to fuel injectors.

If the injectors are not actuating, the troubleshooting is as follows:

- Disconnect all electrical plugs from fuel injectors.
- Bridge contacts of one plug with US 1115 L.E.D. tester.
- Operate starter briefly (the diode must flicker) and repeat procedure on remaining plug contacts.

**Note:** If diode does not flicker, reverse test leads and repeat procedure to insure correct polarity of tester connections.

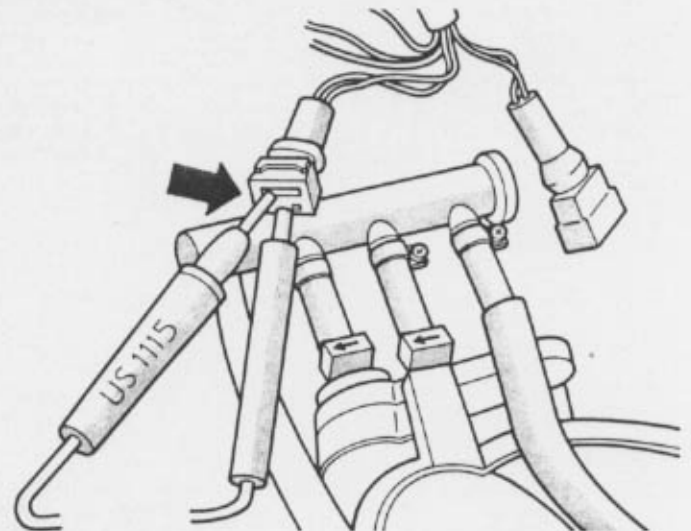

# Checking/Adjusting

---

## Fuel Injectors — Checking (Cont'd.)

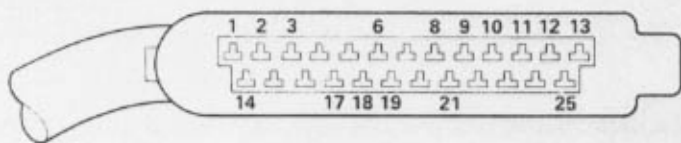

- Connect ohmmeter to terminals 12 and 14 of the multi-pin connector plug. This will check the total resistance of all 4 injectors including wiring to the E.C.U. and power supply relay. Resistance reading should be approximately 3-5 ohms.

If total resistance is OK, replace E.C.U.

If total resistance is not OK, replace harness.

**Note:** Since the internal resistance of the measuring instruments and the ambient temperature have a large influence on the readings, the test should be conducted with a digital multimeter.

## Throttle Switch — Checking And Adjusting

### Wiring And E.C.U. Check

- Coolant temperature above 60°C (140°F)
- Turn ignition ON
- Disconnect throttle switch connector (#2 in illustration)
- Check voltage across the two female connectors (wiring to E.C.U.)

**Note:** Do not use test light for checking either voltage or throttle switch operation because damage to the circuitry of the E.C.U. will result.

- Voltage should be approximately 5 volts

If no, check wiring/connectors to E.C.U. for breakage or poor connection. Reconnect throttle switch and connect ohmmeter between terminals 6 and 11 (4 and 7 for Digijet System) of E.C.U. multi-pin connector plug. Reading should be approximately 0 ohms with throttle in fully closed or fully open position. If OK, replace E.C.U.

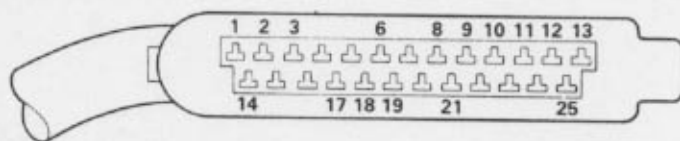
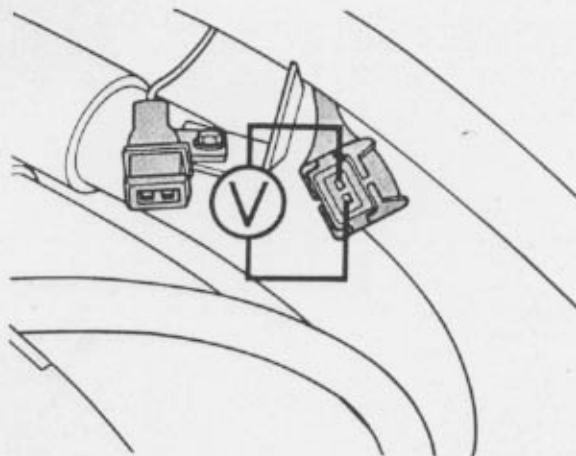



# Checking/Adjusting

## Throttle Switch — Checking And Adjusting (Cont'd.)

### Idle Switch

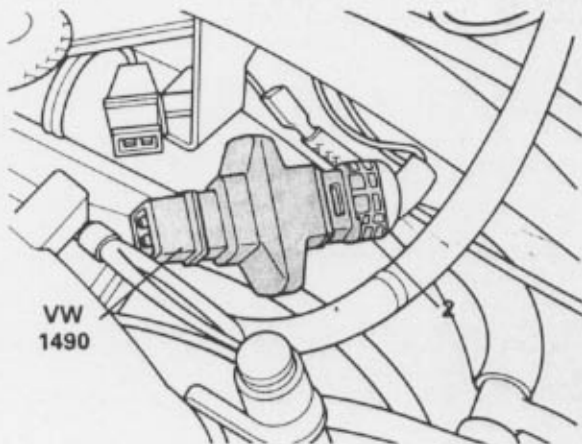
- Results of previous checks must be OK
- **Temperature at coolant temperature sensor must be a minimum of 60°C (140°F) and resistance of the sensor must be 550 ohms or less.**



- Disconnect throttle switch connector (#2 in illustration)
- Bridge the two female connectors of wiring harness to E.C.U. together using bridge  end of tool VW 1490.
- Start engine.
- Raise engine speed above 3000 RPM and return to idle
- Operate throttle valve by hand and **slowly** open throttle valve slightly
  - Engine speed must fluctuate (surge)If no, replace E.C.U.  
If okay, go to next step

### Full Throttle Switch

- Results of previous checks must be OK

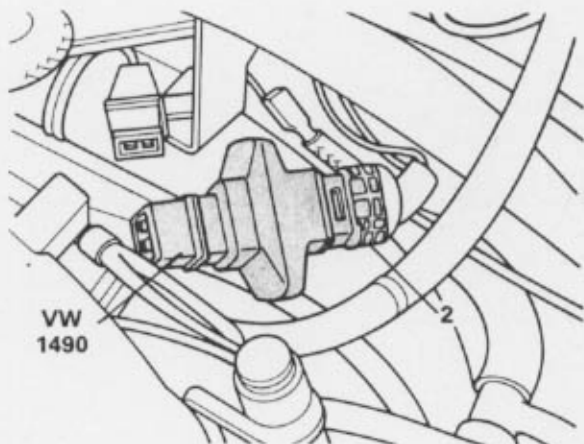

- **Temperature at coolant temperature sensor must be a minimum of 60°C (140°F) and the resistance 550 ohms or less.**
- Connect CO tester, W 1367, and VW 1473
- Start engine and let idle for approximately two minutes.
- Disconnect throttle switch connector (#2 in illustration)
- Slowly increase engine speed to approximately 4500 RPM
  - CO must read 0.3 - 1.1% Vol. (Note reading)
- With engine speed at 4500 RPM bridge female terminals of throttle switch connector using bridge  end of tool VW 1490
  - CO reading must increase in volume by approximately 1% (or more).If no, replace E.C.U.  
If okay, continue to next page

## Throttle Switch — Checking And Adjusting (Cont'd.)

### To Adjust:

- Disconnect throttle switch connector
- Connect ohmmeter to the two male connectors from throttle switch (#1)
- Start engine,  
Ohmmeter reading must be '0' ohms at idle
- Slightly open throttle, ohmmeter reading should go to infinity ( $\infty$ ) ohms
- **Slowly** close throttle to idle position  
Ohmmeter reading must return to '0' ohms

**Note:** Correct adjustment is very important. If switch is mis-adjusted, engine may surge or cut-out during steady or light acceleration.

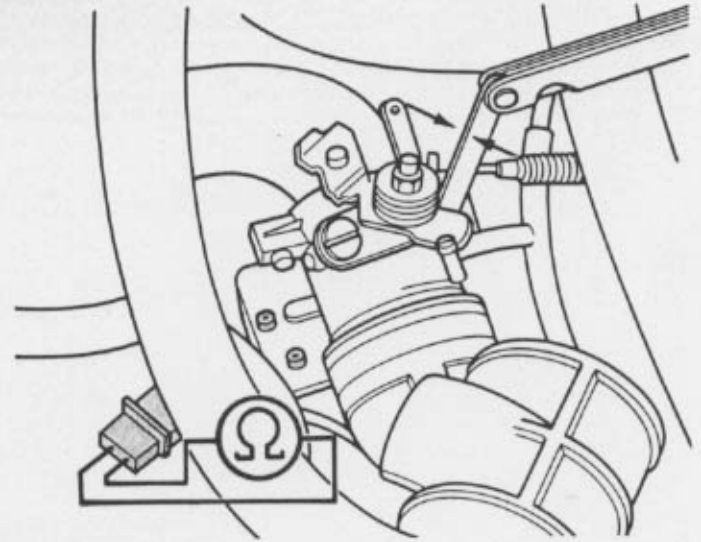

- Stop engine
- Using accelerator pedal, open throttle fully, ohmmeter must read infinity ( $\infty$ ) ohms
- If ohmmeter readings are not correct, adjust throttle switch

### To Adjust:

- Loosen Allen Head retaining screw slightly (#2)
- Open throttle valve and slowly close
- Measure switch point with feeler gauge between idle-stop and idle-stop screw (Gap A)

- At point switch contacts close, Gap A must be between 0.05 - 0.10 mm (.002 - .004 in.)

If not, correct by adjusting position of switch using Allen Head cam-screw (#3). Do not tamper with setting of idle-stop screw.

- Tighten retaining screw (#2)
- **Recheck adjustment using engine RPM method above.**

If ohmmeter readings are correct: reinstall throttle switch connector and continue

If not okay: replace throttle switch



# Checking/Adjusting

## Oxygen Sensor — Checking

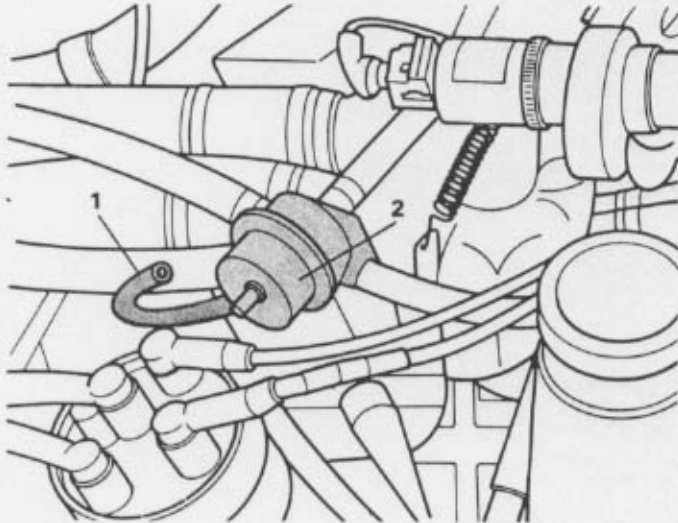

Engine at operating temperature, check oxygen sensor as follows:

- Start engine - run for 2 minutes
- Oxygen sensor connected
- Remove hose (1) from pressure regulator (2) and plug hose

- CO should increase briefly, then drop in value to 0.3-1.1%

If no: Proceed to determine whether the problem is with the oxygen sensor or with the E.C.U.

- Shut off engine
- Disconnect oxygen sensor

**Note:** The oxygen sensor must be disconnected with the ignition off, to cancel the memory in the electronic control unit (E.C.U.)

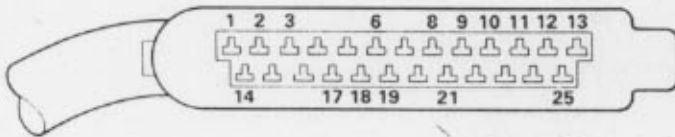

- Start engine
- Hold disconnected oxygen sensor wire from E.C.U. to ground

- CO content must rise

If no: Check for continuity of wiring to E.C.U terminals 2 and 13 as per Page 129 — System Check with volt/ohmmeter

If continuity is okay, replace E.C.U.

## Ignition System — Checking

If no spark is present at terminal #4 of the ignition coil when cranking, perform the following checks:

- 1 - Check for battery voltage at terminal 15 of ignition coil with ignition on.  
If no: trace and correct fault.
- 2 - If yes: correct US 1115 L.E.D. tester to terminal 1 of ignition coil and crank engine. Diode must flash while cranking.  
If yes: replace ignition coil  
If no: check Hall system as follows:

### Part A

- Remove the wiring connector from the distributor
- Switch the ignition on
- Measure voltage at outer terminals of wiring connector
  - Reading should be a minimum of 5 volts. If voltage is present, go to **Part B** (next page)

If voltage is not present at the outer terminals, remove the wiring connector from the fuel injection E.C.U. and check for voltage across terminals 13 and 14.

If battery voltage is present, check for continuity between terminal 6 of the fuel injection E.C.U. and the brown/white wire at the distributor wiring connector and terminal 8 of the E.C.U. and the red/black wire at the distributor wiring connector

If wiring is OK, replace the fuel injection E.C.U. and retest

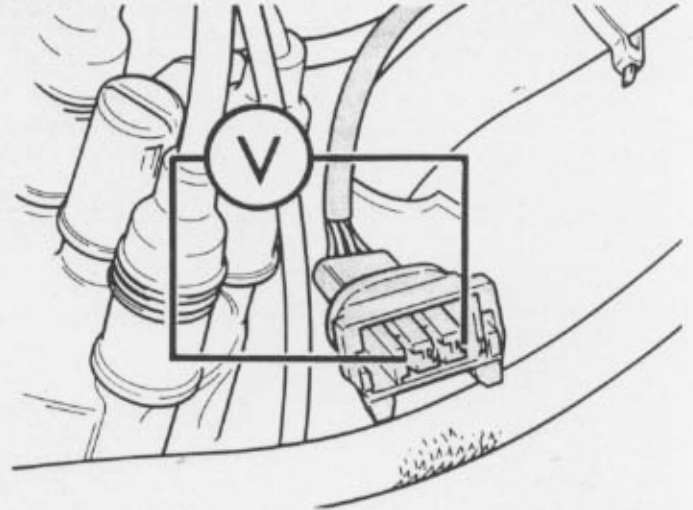

# Checking/Adjusting

## Ignition System — Checking (Cont'd.)

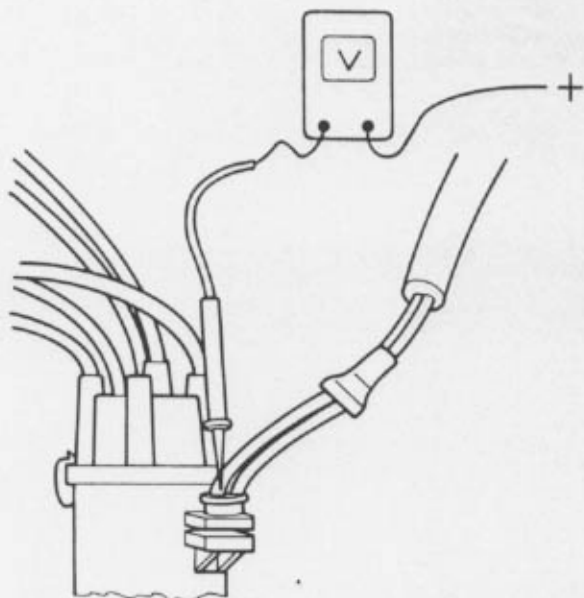

### Part B

- Reconnect wiring connector to distributor and peel back rubber boot
  - Connect a voltmeter between the center terminal of the wiring connector and battery (+)
  - Crank engine
    - Voltmeter reading should fluctuate
- If not, replace Hall sender and retest
- If voltage reading fluctuates, check continuity of the wiring between the center terminal (green wire) of the distributor wiring connector and terminal 18 of E.C.U.
- If wiring is OK, replace E.C.U.

## Idle Stabilization — Checking

- Engine at operating temperature, oil temperature at least 80°C/176°F.
- Throttle switch connected and functioning properly.
- All electrical consumers must be off during checking procedure. Coolant fan should not be running when observing readings.
- Connect multi-meter US 1119 (or equivalent) to idle stabilization valve using test adapter VW 1315A/2. Set range of meter to 2 amp scale (readings will be in milliamperes).
- Run engine at idle and observe reading. Basic idle value should be 430 ± 15 mA. If no: go to Idle Speed/CO Content — Checking and Adjusting.

- If you have a fixed (non-fluctuating milliamp reading and the idle is high (approximately 1100 - 1200 RPM), check for signal from terminal 1 of ignition coil at connector plug for idle stabilizer control unit. Connect US 1115 L.E.D. tester between terminals 5 and 17 of connector plug. L.E.D. tester should flash while cranking.

If yes: replace idle stabilization control unit and proceed.

If no: repair open circuit between terminal 1 of ignition coil and terminal 17 of idle stabilization control unit plug.

If you have no milliamp reading and idle is low and/or surging, check for power to idle stabilization control unit from terminal 87 of power supply relay. Connect US 1115 L.E.D. tester between terminals 5 and 14 of idle stabilization control unit plug. L.E.D. tester should come on when ignition is switched on.

If no: repair open circuit between terminal 87 of power supply relay and terminal 14 of idle stabilization control unit plug.

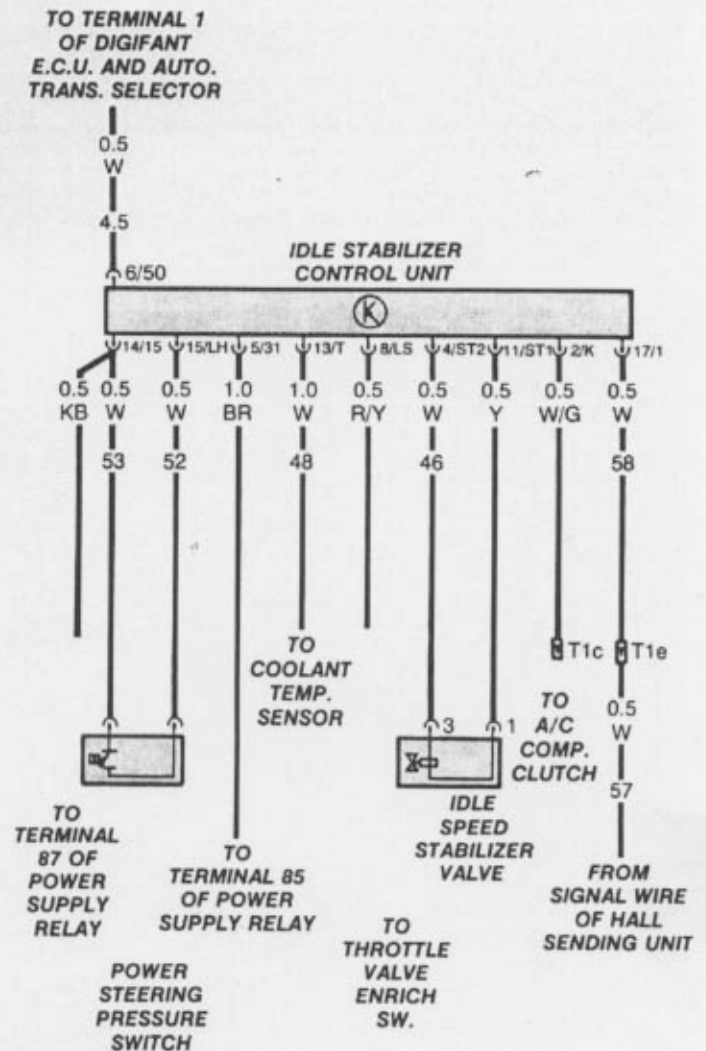

# Checking/Adjusting

## Idle Stabilization — Checking (Cont'd.)

**Note:** The following tests should be done with a partner performing the specified operations while you observe the milliamperage readings. The drive wheels

should be raised off the ground during operations which require that the vehicle be in gear.

### Automatic Transmission

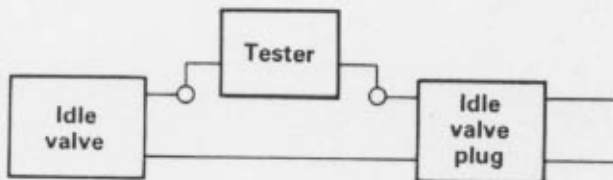
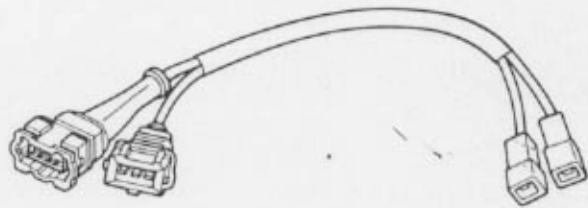

- Connect VW 1315/2 and US 1119 to idle stabilizer valve, set meter to mA scale
- Engine idling, with handbrake firmly engaged, place gearshift lever in drive. While observing multi-meter:  
Milliamp reading should increase.

If no: remove idle stabilization control unit. Connect US 1119 multi-meter between terminals 5 and 6 of connector plug for idle stabilization control unit and set to 2 volt range. Run engine at idle. Reading should be 0 volts in park or neutral (0.1 volt is acceptable), and increase to between 0.5 to 1.0 volt when placed in any drive gear.

If yes: replace idle stabilization control unit.

If no: locate and repair problem from neutral safety switch to terminal 6 of connector plug for idle stabilization control unit.

(Consult Vanagon Wiring Diagram Book)

### Air Conditioning

- Engine idling, turn on A/C while observing multi-meter.
  - Milliamp reading should increase.
- If no: remove idle stabilization control unit. Connect US 1115 L.E.D. tester between terminals 2 and 5 of connector plug for idle stabilization control unit. Start engine and switch A/C on and off. L.E.D. must light

when A/C is on, and off when A/C is off.

If yes: replace idle stabilization control valve.

If no: ensure that A/C compressor clutch is functioning properly, repair, if necessary, and re-test. Check wiring from A/C compressor clutch to terminal 2 of connector plug for idle stabilization unit.

## Idle Stabilization System — Checking (Cont'd.)

### Power Steering

- Engine idling, turn steering wheel hard left (or right) to stop while observing multi-meter.
  - Milliamp reading should increase.
- If no: remove idle stabilization control unit. Connect US 1115 L.E.D. tester to terminals 5 and 15 of connector plug. Start engine and turn wheels hard left (or right) to stop. L.E.D. tester must come on with wheels turned hard to stop.
- If yes: replace idle stabilization control unit.
- If no: check operation of power steering pressure switch. Switch must close with engine running and wheels turned hard to stop.
- If no: replace power steering pressure switch.
- If yes: check power steering pump pressure.

**Note:** The amount of increase in the milliamp readings for the preceding steps is dependent upon numerous factors. Of primary concern is that the milliamp readings do increase for each step, which indicates that the idle stabilization control unit is compensating for the prescribed load change.

- **If the idle stabilization control unit is functioning properly, but the idle drops drastically or engine stalls when a load is applied, the problem is with the idle stabilizer valve itself.**

# Checking/Adjusting

## Evaporative Emission System — Checking Control Valve

- Run engine at idle (engine at normal operating temperature).
- Remove white nylon purge line from rubber boot at right rear of intake air distributor. Attach hand-operated vacuum pump US 8026 to open end of purge line, and apply 5-10" of vacuum. Control valve should retain vacuum. If no:
- Remove purple vacuum line from fitting on throttle valve housing and install vacuum gauge on fitting. At idle, there must be less than 1" of vacuum available at fitting.  
If no: adjust throttle valve stop screw as per Page 128 and repeat this check.
- Repeat first two checks; control valve retains vacuum at idle. Accelerate engine by hand, control valve must release vacuum.  
If no: Either vacuum fitting on throttle valve housing is plugged or control valve is stuck in closed position.

## Evaporative Emission System — Checking For Leaks

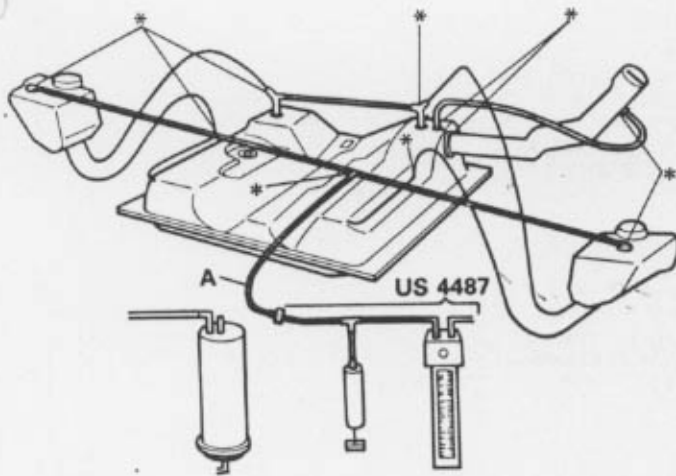

- Remove small hose "A" from top of charcoal filter. Connect to leak tester US 4487.
- Set leak tester scale to "0".
- Pressurize system with hand pump to 3.3 cm of mercury.
  - system okay if pressure is 2.54 cm or greater after 5 minutes.
  - system leaking if pressure drops below 2.54 cm after 5 minutes.

**Note:** Check system for leaks using soap solution at spots marked with \*. Seal if necessary.

# Basic Checks/Adjustments

## Specifications/Adjustments

### Basic Settings

Test and adjustment conditions:

- Engine oil temp. min 80°C (176°F)
- All electrical consumers turned off (radiator fan should not be running while performing checks or adjustments)
- Crankcase breather hose removed from breather valve and plugged
- Throttle valve switch operating properly (**closed when in idle position**)
- Idle stabilizer operating properly (with ignition turned on, valve should vibrate and hum)

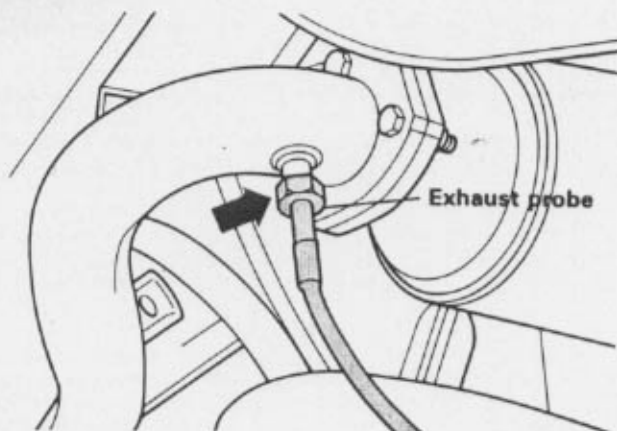

Connecting test equipment:

#### WARNING

Ignition must be turned off when connecting test equipment

- Connect **VW 1367** tester for ignition timing and rpm display functions
- Using adapter **VW 1473**, connect tester **VW 1367** to terminal 1 of ignition coil
- Connect **CO** tester to adapter on left exhaust pipe using Sun tool **120.239**

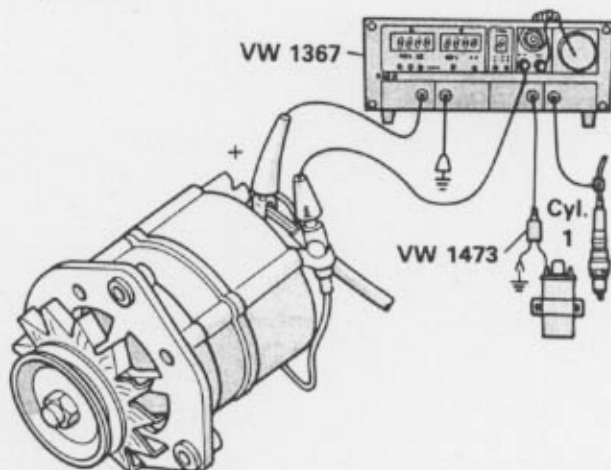



# Basic Checks/Adjustments

## Specifications/Adjustments (Cont'd.)

Terminal #1 input to  
idle stabilization control unit  
(Left side of engine compartment)

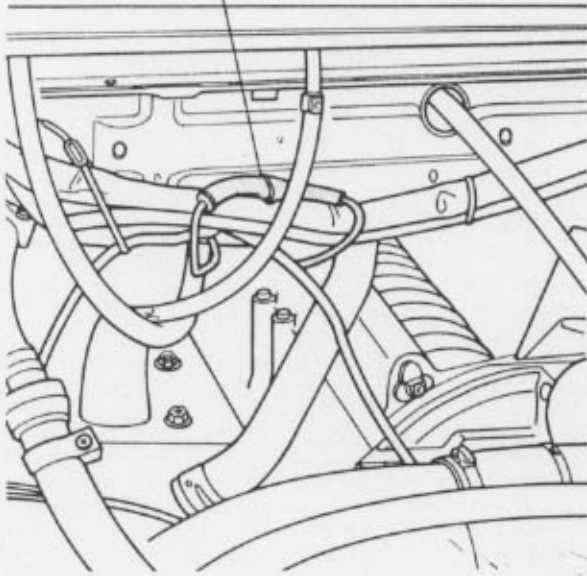

**Note:** Proper sequence for checking/adjusting basic settings is ignition timing, idle speed, and CO content.

### Ignition Timing — checking and adjusting:

- Engine idling  
Disconnect coolant temperature sensor and terminal 1 input to idle stabilization control unit (illustration). (Caution — do not let connector hang down onto exhaust manifold.) Engine speed will increase to approximately 2000-2500 RPM (Note: Manually increase engine speed to this specification if necessary): timing specification is  $5^{\circ} \pm 2^{\circ}$  BTDC. If out of specification adjust to  $5^{\circ} \pm 1^{\circ}$  BTDC.
- Reconnect coolant temperature sensor and terminal 1 input to idle stabilization control unit.
- Increase engine speed to 3500 RPM:
  - Specification is  $35 \pm 5^{\circ}$  BTDC.

### Idle Speed and CO Content — checking and adjusting:

All test conditions as outlined on previous page have been checked and are in order.

- **With ignition switched off**, disconnect oxygen sensor. The oxygen sensor must be disconnected with the ignition off in order to cancel a memory function in the E.C.U.
- Connect multi-meter US 1119 (or equivalent) to idle stabilization valve using test adapter VW 1315A/2. Set range of meter to measure a minimum of 2 amps of current (readings will be in milliamperes).
- Run engine at idle and observe reading. Milliamp reading should be 410-450 mA for idle stabilizer, with idle speed of approximately 880 + 50 RPM (coolant fan not running).  
If no: adjust to specifications by turning idle screw on throttle housing.

# Basic Checks/Adjustments

## Specifications/Adjustments (Cont'd.)

- Reconnect terminal #1 input to idle stabilizer control unit.
- Disconnect harness plug from idle stabilizer valve. Idle should remain relatively steady at 880 + 50 rpm (no major drop in idle speed when plug is disconnected), (coolant fan not running).
- Reconnect harness plug to idle stabilizer.
  - Observe CO reading: CO content must correspond according to elevation chart. Use chart to find correct value.

Example: At 1600 meters (approx. 1 mile) CO should be 5% ±.5%.

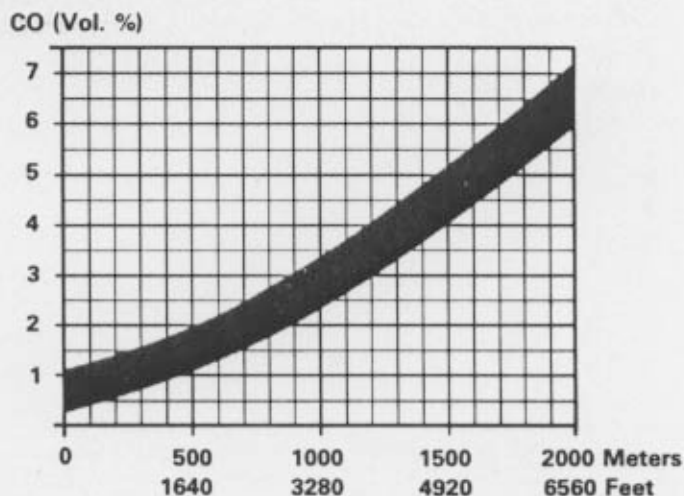

### Note:

For CO adjusting, remove screw cap as follows:

- Drill CO adjusting screw cap using 2.5 mm (0.098 in.) drill
- Thread 3 mm (0.137 in.) sheet metal screw into drilled hole
- Grasp screw with pliers, pull out cap
  - Recheck idle speed/milliamperes adjustment, correct if necessary.
  - Recheck CO content, adjust if necessary.
  - Repeat procedure until both idle setting, and CO content are within specifications.
  - Reconnect oxygen sensor: CO% must return to normal specification: 0.3 to 1.1%.

If no: go to Page 118, Oxygen Sensor — Checking.

# Basic Checks/Adjustments

---

## Specifications/Adjustments (Cont'd.)

### Throttle Valve - Basic Adjustment

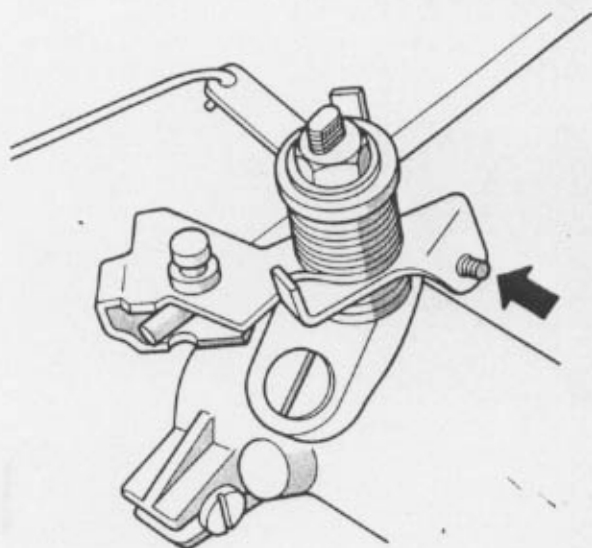

**Note:** Stop screw is set at factory and should not be moved. If screw position has been altered, check basic adjustment as follows:

Work Sequence:

- Turn adjusting screw (arrow) out until gap exists between stop and screw
- Turn screw in until it touches stop

**Note:** In order to determine exact point of contact with screw stop, place a thin piece of paper between screw and stop. Slide paper and turn screw at same time until screw pinches paper.

- Turn screw clockwise additional 1/2 turn.
- Check idle speed and CO content: adjust if necessary

# Electrical Testing

## System Check With Volt/Ohmmeter

Entire electrical system can be checked by disconnecting multi-pin connector of control unit.

OHMMETER TO TERMINAL:	COMPONENTS	CHECKS/TEST CONDITIONS	SPECIFICATIONS
2 and 13	Oxygen Sensor	<ul style="list-style-type: none"> <li>• Connector Disconnected and Grounded</li> <li>• Connector Connected</li> </ul>	0 ohms $\infty$ ohms
6 and 9	Temp. Sensor I (Intake Air Temp.)	• Resistance	Corresponding with graph shown below
6 and 10	Temp. Sensor II (Coolant Temp.)	• Resistance	
6 and 11	Throttle Switch	<ul style="list-style-type: none"> <li>• Idle Position</li> <li>• Full Throttle Pos.</li> </ul>	0 ohms 0 ohms
6 and 17	Air Flow Sensor	• Resistance/Potentiometer	500-1000 ohms
12 and 14	Fuel Injectors	• Resistance	Approx. 3-5 ohms
17 and 21	Air Flow Sensor	• Resistance/Potentiometer	Ohms fluctuate as sensor plate is opened
Check at Components	Individual Fuel Injectors	Resistance	14 to 18 ohms
13 and Ground	Control Unit Ground Connection	Wiring	0 ohms
VOLTMETER TO TERMINAL:	COMPONENTS	CHECKS	SPECIFICATIONS
1 and 13	<ul style="list-style-type: none"> <li>• Wiring From Starter</li> <li>• Starting Injection/Enrichment</li> </ul>	• Voltage at Terminal 50 During Cranking	Cranking voltage
3 and 13 Bridged	Fuel Pump Relay	• Ignition ON	Fuel pump runs
13 and 14	Power Supply Relay	• Ignition ON	Battery voltage

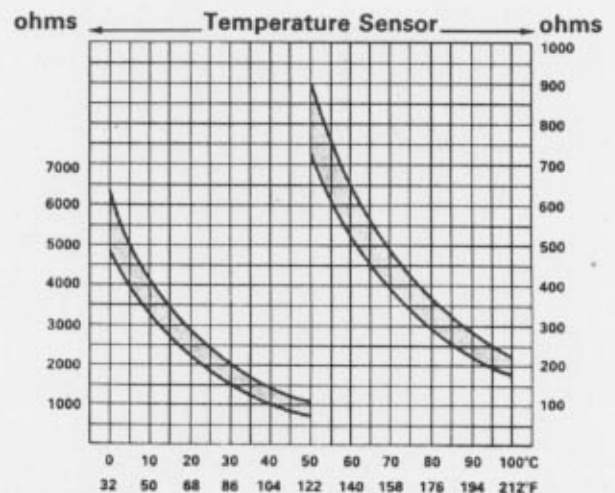
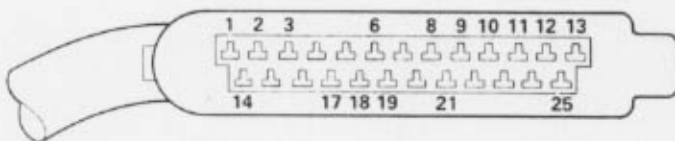

# Wiring Diagram

30  
15  
X  
31

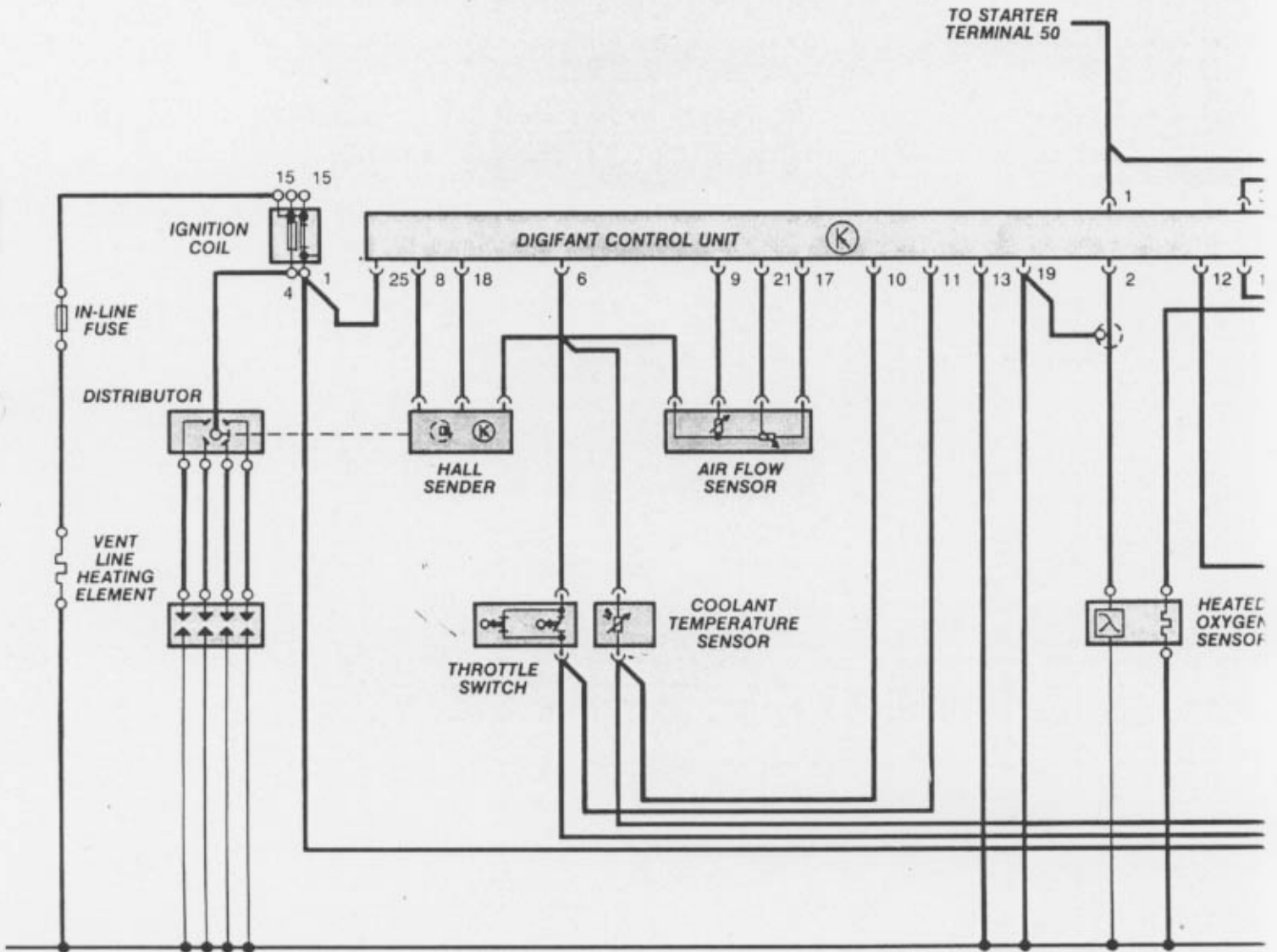

# Wiring Diagram

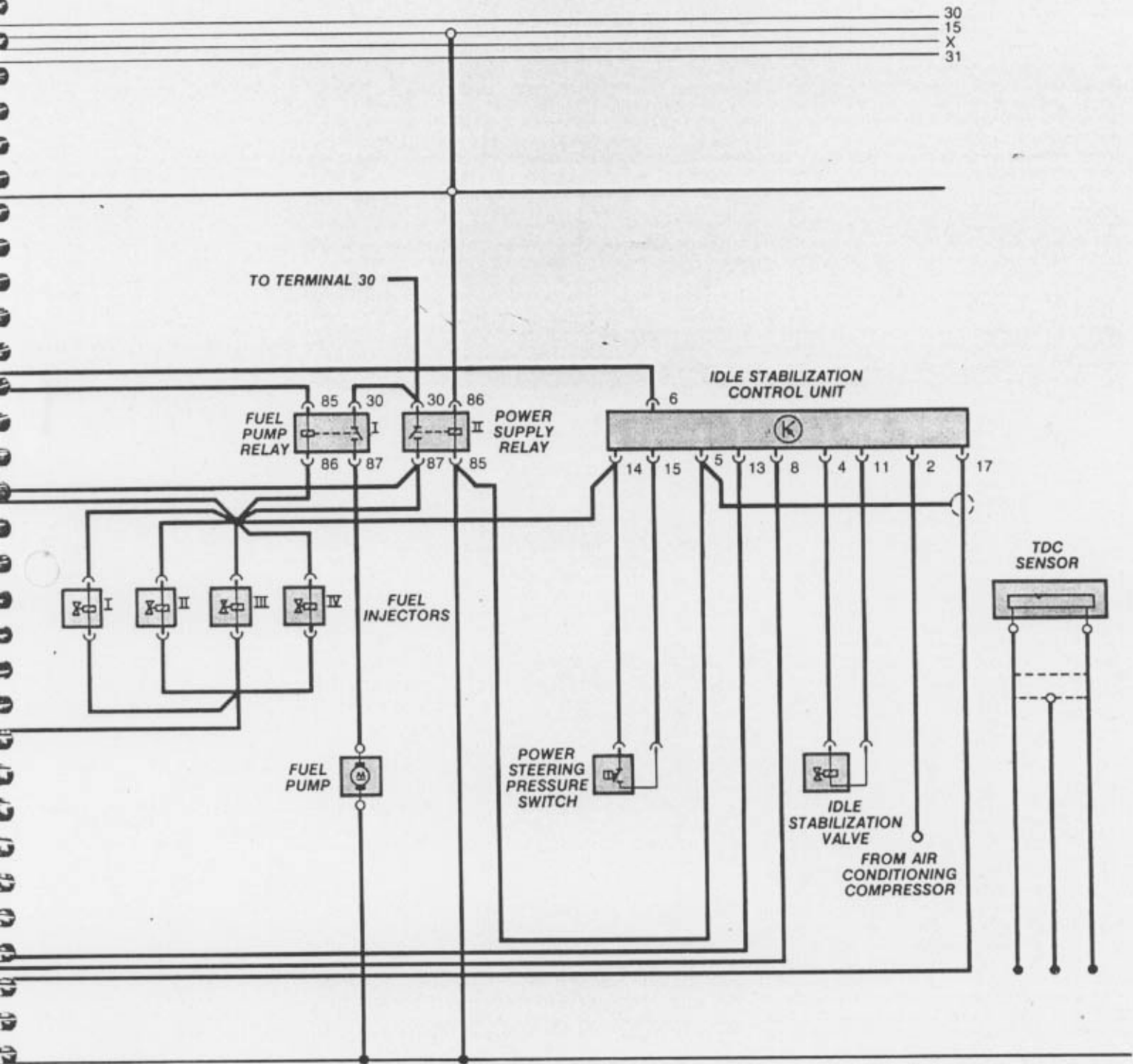

# Glossary/Component Location

---

## **AIR FLOW SENSOR**

Measures the amount of air entering the intake manifold and sends a voltage signal to the electronic control unit. Location: attached to air filter housing.

## **BAR**

Unit of measurement pressure — 1 bar is approx. 14.5 PSI.

## **COOLANT TEMPERATURE SENSOR**

A sensor for measuring engine coolant temperature to determine cold running engine operation. Location: left, lower side of thermostat housing.

## **ELECTRONIC CONTROL UNIT (E.C.U.)**

Provides the proper actuation signal to the injectors and optimum ignition timing point based on inputs from other system components. Location: under left side of rear seat (inside vehicle).

## **FUEL FILTER**

A filter which removes foreign particles from the fuel system. Location: inboard side of right frame member, directly behind fuel pump.

## **FUEL STRAINER**

A strainer which removes foreign particles from the fuel system. Location: in front of fuel pump (between fuel tank and fuel pump).

## **FUEL PUMP**

An electric pump which delivers fuel to the injectors. Location: inboard side of right frame member, directly behind fuel tank.

## **FUEL PUMP RELAY**

When energized by power supply relay and grounded by E.C.U., provides battery voltage to fuel pump. Location: right side relay inside black plastic relay box, directly above ignition coil on left side of engine compartment.

## **IDLE STABILIZATION CONTROL UNIT**

Controls operation of idle stabilization valve based on pre-programmed idle speed values and various other component inputs. Location: behind right rear taillight assembly, mounted just forward of air cleaner intake hose.

## **IDLE STABILIZATION VALVE**

Electronically controlled valve used to maintain idle speed at a pre-determined level by regulating intake air at idle. Location: rubber mounted to top of intake air distributor.

## **INJECTOR**

Electronically activated valve which directs a cone shaped mist of fuel into the intake port near each intake valve. Location: mount into intake manifold at cylinder head.

## **OXYGEN SENSOR**

Used to detect the amount of oxygen in the exhaust gases. Location: threads into catalytic converter housing.

## **OXYGEN SENSOR MILEAGE COUNTER**

Activates a warning light to indicate oxygen sensor replacement is required. Location: next to left side radius rod in front of vehicle.

## **POWER SUPPLY RELAY**

When energized by ignition switch, provides battery voltage to E.C.U., injectors, idle stabilization control unit, fuel pump relay, oxygen sensor heater element, and power steering pressure switch. Location: left side relay inside black plastic relay box, directly above ignition coil on left side of engine compartment.

## **PRESSURE REGULATOR**

A diaphragm type regulator used to maintain system pressure at a given value. Location: bolted to rear of intake air distributor, directly adjacent to ignition distributor.

## **AIR FLAP POTENTIOMETER**

A variable resistor connected to the air flow sensor that provides a signal for determining fuel system enrichment. Location: internal component of air flow sensor (not available separately).

## **RESIDUAL PRESSURE**

Fuel pressure in the fuel injection lines after the engine has been turned off.

## **THROTTLE SWITCH**

Provides closed throttle and full throttle signals to E.C.U. for idle stabilization, deceleration fuel shut-off, and full load enrichment. Location: mounted to underside of throttle valve housing.